

MCS 2000 Mobile Radio Service Instructions

Volume 2d

900-MHz Frequency Range Specific

Safety Information

Every radio, when transmitting, radiates energy into the atmosphere which may, under certain conditions, cause the generation of a spark.

All users of vehicles fitted with radios should be aware of the following warnings:

Do not operate radio near flammable liquids or in the vicinity of explosive devices.

To ensure personal safety, please observe the following simple rules:

Check the laws and regulations on the use of two-way mobile radios in the areas where you drive. Always obey them. Also, when using your radio while driving, please:

- Give full attention to driving,
- Use hands-free operation, if available and
- Pull off the road and park before making or answering a call if driving conditions so require.

Airbag Warning

VEHICLES EQUIPPED WITH AIR BAGS

An air bag inflates with great force. DO NOT place objects, including communication equipment, in the area over the air bag or in the air bag deployment area. If the communication equipment is improperly installed and the air bag inflates, this could cause serious injury.

Installation of vehicle communication equipment should be performed by a professional installer/technician qualified in the requirements for such installations.

An air bag's size, shape and deployment area can vary by vehicle make, model and front compartment configuration (e.g., bench seat vs. bucket seats). Contact the vehicle manufacturer's corporate headquarters, if necessary, for specific air bag information for the vehicle make, model and front compartment configuration involved in your communication equipment installation.

LP Gas Warning

It is mandatory that radios installed in vehicles fuelled by liquefied petroleum gas conform to the National Fire Protection Association standard NFPA 58, which applies to vehicles with a liquid propane (LP) gas container in the trunk or other sealed off space within the interior of the vehicle. The NFPA58 requires the following:

- Any space containing radio equipment shall be isolated by a seal from the

space in which the LP gas container and its fittings are located.

- Removable (outside) filling connections shall be used.
- The container space shall be vented to the outside.

Anti-Lock Braking System (ABS) and Anti-Skid Braking System Precautions



WARNING

Disruption of the anti-skid/anti-lock braking system by the radio transmitter may result in unexpected vehicle motion.

Motorola recommends the following radio installation precautions and vehicle braking system test procedures to ensure that the radio, when transmitting, does not interfere with operation of the vehicle braking system.

Installation Precautions

1. Always provide as much distance as possible between braking modulator unit and radio, and between braking modulator unit and radio antenna and associated antenna transmission line. Before installing radio, determine location of braking modulator unit in vehicle. Depending on make and model of vehicle, braking modulator unit may be located in trunk, under dashboard, in engine compartment, or in some other cargo area. If you cannot determine location of braking modulator unit, refer to vehicle service manual or contact a dealer for the particular make of vehicle.
2. If braking modulator unit is located on left side of the vehicle, install radio on right side of vehicle, and conversely.
3. Route all radio wiring including antenna transmission line as far away as possible from braking modulator unit and associated braking system wiring.
4. Never activate radio transmitter while vehicle is in motion and vehicle trunk lid is open.

Braking System Tests

The following procedure checks for the most common types of interference that may be caused to vehicle braking system by a radio transmitter.

1. Run vehicle engine at idle speed and set vehicle transmission selector to PARK. Release brake pedal completely and key radio transmitter. Verify that there are no unusual effects (visual or audible) to vehicle lights or other electrical equipment and accessories while microphone is NOT being spoken into.
2. Repeat step 1. except do so while microphone IS being spoken into.
3. Press vehicle brake pedal slightly just enough to light vehicle brake light(s). Then repeat step 1. and step 2.
4. Press the vehicle brake pedal firmly and repeat step 1. and step 2.
5. Ensure that there is a minimum of two vehicle lengths between front of vehicle and any object in vehicle's forward path. Then, set vehicle

transmission selector to DRIVE. Press brake pedal just far enough to stop vehicle motion completely. Key radio transmitter. Verify that vehicle does not start to move while microphone is NOT being spoken into.

6. Repeat step 5. except do so while microphone IS being spoken into.
7. Release brake pedal completely and accelerate vehicle to a speed between 15 and 25 miles/25 and 40 kilometers per hour. Ensure that a minimum of two vehicle lengths is maintained between front of vehicle and any object in vehicle's forward path. Have another person key radio transmitter and verify that vehicle can be braked normally to a moderate stop while microphone is NOT being spoken into.
8. Repeat step 7. except do so while microphone IS being spoken into.
9. Release brake pedal completely and accelerate vehicle to a speed of 20 miles/30 kilometers per hour. Ensure that a minimum of two vehicle lengths is maintained between front of vehicle and any object in vehicle's forward path. Have another person key radio transmitter and verify that vehicle can be braked properly to a sudden (panic) stop while microphone is NOT being spoken into.
10. Repeat step 9. except do so while microphone IS being spoken into.
11. Repeat step 9. and step 10. except use a vehicle speed of 30 miles/50 kilometers per hour.

LIST OF EFFECTIVE PAGES

MCS 2000 Mobile Radio Service Instructions

Volume 2d

900-MHz Frequency Range Specific Information

Motorola Publication Number 68P81080C44-B

Issue Dates of Original and Revised Pages are:

Revision O: March 1996

Revision A: November 1996

Revision B: May 1998

The Number of pages in this publication is 104 consisting of the following:

<u>Page Number</u>	<u>Revision Letter</u>	<u>Page Number</u>	<u>Revision Letter</u>
Front cover	O	1 through 90	B
Inside front cover (blank)	O	Questionnaire (Front)	O
Title	B	Questionnaire (Back)	O
Safety 0 through Safety 2	B	Inside Back Cover (Replacement Parts Ordering)	B
A and B	B	Back Cover (Not Marked with Revision Letter	A
i and ii	B		

Note: The letter O in the Revision Letter column of the table above denotes an original page. Original pages ARE NOT identified as such in the page footors except by the absence of a change letter and date.

NOTES

Table of Contents

- Safety Information Safety 0
- List of Effective Pages A
- List of Figures ii
- List of Tables. ii

- 1- Introduction 1
- 2- Theory of Operation 5
 - Introduction 5
 - Block Diagram Level Theory of Operation. 6
 - Receiver Detailed Functional Description 9
 - Transmitter Detailed Functional Description. 12
 - Synthesizer Detailed Functional Description. 15
 - Controller Detailed Functional Description. 17
 - Dc Power Control and Regulation Detailed Functional Description. 17
- 3 - Troubleshooting 19
- 4 - Reference Drawings 33

List of Figures

Figure 1. 900-MHz Radio Functional Block Diagram 7

Figure 2. Transceiver Board Section Locations 34

Note: Troubleshooting charts are listed on page 19; Component location illustrations, schematic diagrams, and parts lists are listed on page 33.

List of Tables

Table 1. Transceiver Board Kit Numbers v.s. Service Manual Page Numbers for Specific Information 3

Table 2. Schematic Diagrams Interconnection List 59

Introduction

1

This publication (Service Manual Volume 2d, Motorola Publication 68P81080C44) provides frequency-range-specific information for the 12-Watt and 30-Watt MCS 2000 radios for which the transceiver board kit numbers are listed in Table 1. These radios all operate in the 900-MHz frequency range. The coverage in this publication includes both non-data-capable and data-capable radios.

This publication is a companion volume to Service Manual Volume 1 for MCS 2000 Radios, Motorola Publication 68P81083C20, which provides non-frequency-range-specific information for all MCS 2000 Radios. Service personnel must have both Volume 1 and Volume 2a of this Service Manual in order to have all service information for 12-Watt and 30-Watt MCS 2000 Radios that operate in the 900-MHz frequency range.

There are other Volume 2 service manuals (e.g., Volume 2a, 2b, 2c), which cover models of the MCS 2000 Radio for other frequency ranges and power levels. Refer to Volume 1 of this service manual for a list of the manuals related to operation and maintenance of all models of the MCS 2000 Radio, and the Motorola publication numbers for those manuals.

Hereafter in this manual, the MCS 2000 Radio is referred to as the radio. The specific hardware portions of the radio covered in this volume of the service manual are as follows:

- Receiver Front End
- Receiver Intermediate Frequency (IF)
- Receiver Back End
- 12-Watt Power Amplifier
- 30-Watt Power Amplifier
- Synthesizer

This volume (Volume 2d) of the service manual covers the following five topics for the specific hardware portions of the 900-MHz radios:

- Theory of operation
- Troubleshooting
- Component locations
- Parts lists

- Schematic diagrams and associated interconnect information

The five topics listed above for the controller section and for the control heads are covered in Volume 1 of this service manual, Motorola Publication Number 68P81083C20.

All the radios covered in this service manual contain a single circuit card assembly (a printed circuit board with components mounted), which is called the transceiver board. The transceiver board in each version of the radio is identified by a unique Motorola kit number (e.g., FLF5591A). The kit number varies according to the RF output power level of the radio (12-Watts or 30-Watts) and also according to whether or not the radio is data capable. Table 1 on pages 3 and 4 crossreferences each kit number covered in this service manual to the page number where the specified information is located.

Table 1: Transceiver Board Kit Numbers v.s. Service Manual Page Numbers for Specific Information

Kit Number	RF Power Level	Printed Circuit Board (PCB)		Functional Sections Interconnection Information	Controller		Receiver Front End (Page No.)				Receiver Intermediate Frequency (IF) (Page No.)			
		Part No.	Functional Section Locations (Page No.)		Main Controller Section	Power Control Section	Theory of Operation	Trouble shooting Chart	Component Locations and Parts List	Schematic Diagram	Theory of Operation	Trouble shooting Chart	Component Locations and Parts List	Schematic Diagram
FLF5591A, B, C Not Data Capable	12	8404416P04 Issue P4	34	59	Refer to Service Manual Volume 1 Motorola Publication 68P81083C20	Refer to Service Manual Volume 1 Motorola Publication 68P81083C20	9	25	36	37	9	26	38	39
FLF5592A, B, C Not Data Capable	30	8404994E05 Issue P5	34	59			9	25	36	37	9	26	38	39
FLF5604A Data Capable	12	8408559Y01 Issue P1	34	59			9	25	36	37	10	26	40	41
FUF5752A Data Capable	30	8486005J01 Issue P1	34	59			9	25	36	37	10	26	40	41
FLF5952A Data Capable	12	8408497Y01 Issue P2	34	59			9	25	36	37	10	26	40	41
FLF5606A Data Capable	30	8408597Y01 Issue P2	34	59			9	25	36	37	10	26	40	41
HUF1190A Not Data Capable	12	8404416P05 Issue P5	34	59			9	25	36	37	9	26	38	39
HUF1191A Not Data Capable	30	8404994E05 Issue P5	34	59			9	25	36	37	9	26	38	39

Table 1: Transceiver Board Kit Numbers v.s. Service Manual Page Numbers for Specific Information (Continued)

Kit Number	RF Power Level	Printed Circuit Board (PCB) Part No.	Receiver Back End (Page No.)				Synthesizer (Page No.)				Power Amplifier (PA) (Page No.)				
			Theory of Operation	Trouble shooting Chart	Parts List and Component Locations	Schematic Diagram	Theory of Operation	Trouble shooting Chart	Parts List and Component Locations	Schematic Diagram	Theory of Operation	Trouble shooting Chart	Repair	Parts List and Component Locations	Schematic Diagram
FLF5591A, B, C Not Data Capable	12	8404416P04 Issue P4	11	26	42	43	15	27 thru 30	56	57	12	31	N/A	48	49
FLF5592A, B, C Not Data Capable	30	8404994E05 Issue P5	11	26	42	43	15	27 thru 30	56	57	14	32	20	50	51
FLF5604A Data Capable	12	8408559Y01 Issue P1	11	26	42	45	15	27 thru 30	56	57	12	31	N/A	48	49
FUF5752A Data Capable	30	8486005J01 Issue P1	11	26	42	45	15	27 thru 30	56	57	14	32	20	52	53
FLF5952A Data Capable	12	8408497Y01 Issue P2	11	26	42	45	15	27 thru 30	56	57	12	31	N/A	50	51
FLF5606A Data Capable	30	8408597Y01 Issue P2	11	26	42	45	15	27 thru 30	56	57	14	32	20	54	55
HUF1190A Not Data Capable	12	8404416P05 Issue P5	11	26	42	47	15	27 thru 30	56	57	12	31	N/A	48	49

Theory of Operation

2

This chapter provides theory of operation information for the radio. It starts with a block diagram level functional description of the entire radio. This is followed by a detailed functional description for each of the four major functions of the radio.

Introduction

The radio is composed of the following four major functions:

- Receiver
- Transmitter
- Dc Power Control and Regulation
- Operator Interface (Control Head)

The receiver, transmitter, and dc power control and regulation functions are all located on a single circuit card assembly (CCA) in the main body of the radio. The CCA is called the transceiver board. The operator interface function consists of the control head, which plugs into the main body of the radio. There are three different control head types: the Model I for the Model I Radio; the Model II for the Model II Radio; and the Model III for the Model III Radio. The three control heads are covered in their entirety in Volume 1 of this service manual.

The transceiver board in the main body of the radio is physically separated into six functional sections as follows:

- Receiver Front End
- Receiver Intermediate Frequency (IF)
- Receiver Back End
- Power Amplifier (PA)
- Synthesizer
- Controller

The controller section is further divided into two sub-sections: main controller; and power control. The mechanical layout of the transceiver board is illustrated in Chapter 4.

Separate component location diagrams, parts lists, and schematic diagrams are provided in this service manual for each of the six physical sections of the transceiver board and for the control heads.

The component location diagrams, parts lists, and schematic diagrams for the controller section of the transceiver board and for the three types of control heads are located in Volume 1 of this service manual. The component location diagrams, parts lists, and schematic diagrams for the other five physical sections of the transceiver board are located in this volume (Volume 2d).

Block Diagram Level Theory of Operation

The following discussion refers to the functional block diagram for the radio, Figure 1.

The receiver function of the radio detects, demodulates, amplifies, and outputs via the loudspeaker, radio signals picked up by the vehicle or fixed-station antenna. The radio signal input reaches the receiver from the antenna via the antenna switch, which is located in the transmitter function of the radio. The radio signals picked up by the antenna are signals that have been re-broadcast by trunked or conventional repeaters, or that have been broadcast directly by other mobile or fixed station radios.

The receiver function of the radio consists of: the receiver front end section; the receiver intermediate frequency (IF) amplifier section; the receiver back end section; and the audio signal filter (ASFIC) and receiver audio power amplifier circuits in the controller section.

The receiver function of the radio uses the double conversion super-heterodyne design to optimize image rejection and selectivity. The receiver front end section converts the receiver input signal to a first IF of 73.35 MHz. The frequency upon which the receiver operates is determined by a first local oscillator signal generated by the synthesizer section. For the purpose of this discussion, the synthesizer section is considered to be part of the transmitter function of the radio.

The 73.35 MHz IF output signal from the receiver front end section passes through the receiver IF amplifier section where it is filtered and amplified. The output of the receiver IF amplifier section goes to the receiver back end section. In the receiver back end section, which contains the zero intermediate frequency (ZIF) integrated circuit (IC), the receiver IF signal is demodulated to produce receiver audio and squelch signals.

The receiver audio and squelch signal outputs from the receiver back end section are processed by the audio signal filter integrated circuit (ASFIC) in the controller section of the radio to generate receiver audio (filtered) and squelch detect signals. The filtering characteristics and other processes of the ASFIC are controlled by the central processor unit in the controller section.

The receiver audio signal (filtered) from the output of the ASFIC goes to the input of the receiver audio power amplifier circuit, which is located in the controller section of the radio. The receiver audio power amplifier circuit does not pass the receiver audio signal to the loudspeaker until it receives an audio PA enable signal from the controller section of the radio. The reason is that the receiver portion of the radio includes a squelch function, which prevents receiver noise from passing to the loudspeaker during periods of no signal reception.

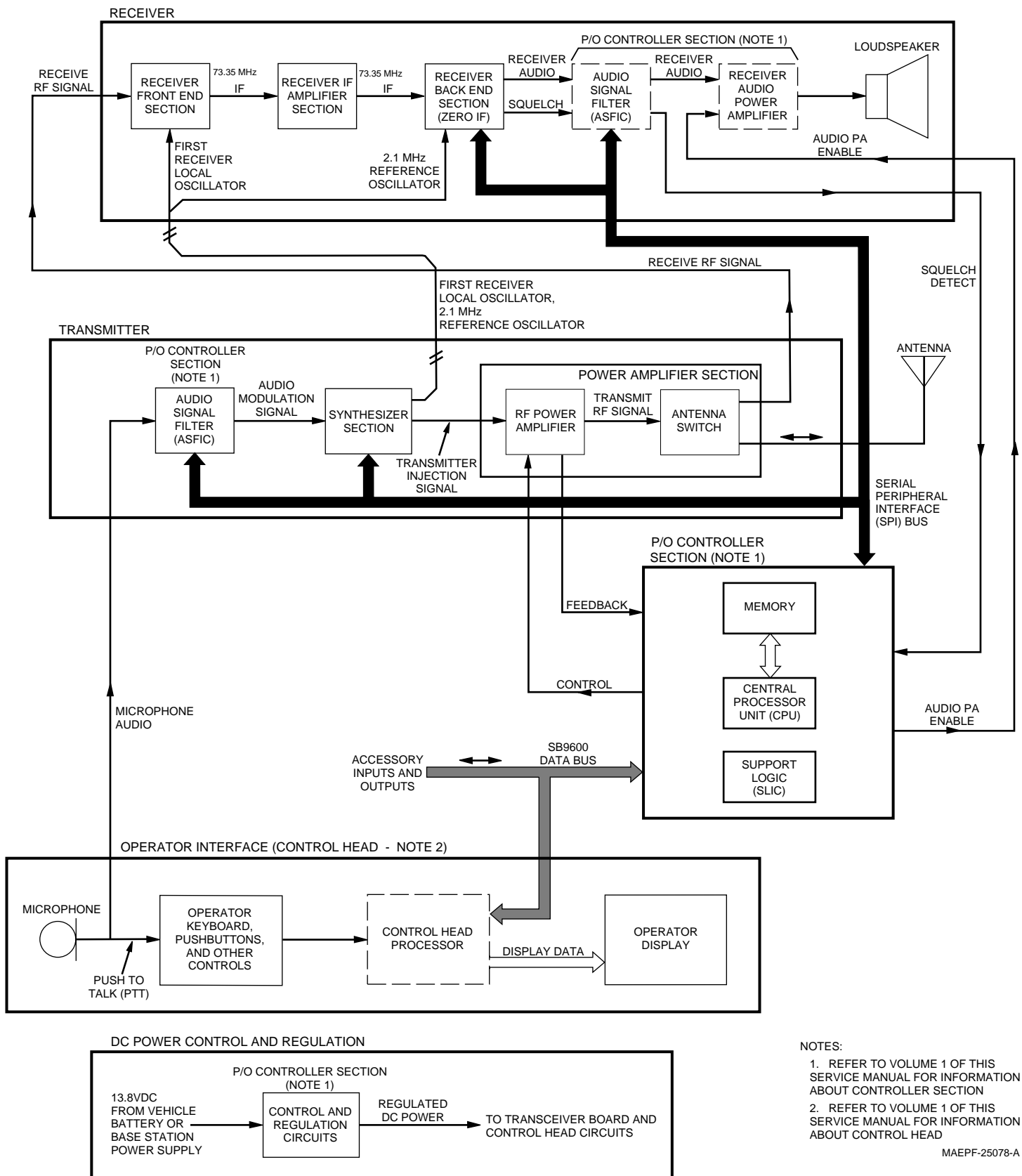

- NOTES:
1. REFER TO VOLUME 1 OF THIS SERVICE MANUAL FOR INFORMATION ABOUT CONTROLLER SECTION
 2. REFER TO VOLUME 1 OF THIS SERVICE MANUAL FOR INFORMATION ABOUT CONTROL HEAD

MAEPF-25078-A

Figure 1 . 900-MHz Radio Functional Block Diagram

The controller generates the audio PA enable signal based on such variables as the level of the received signal, the frequency channel, and the operating mode of the radio. When the audio PA enable signal is generated, the audio power amplifier (PA) is activated and passes the receiver audio signal to the loudspeaker.

The transmitter function of the radio produces either a 12-Watt or a 30-Watt radio frequency output signal, depending on the model of the radio. The radio frequency output signal is frequency modulated by an audio signal from the microphone or from another source such as a telephone keypad or handset.

The transmitter function of the radio consists of: the audio signal filter integrated circuit (ASFIC) in the controller section; the synthesizer section; and the transmitter power amplifier (PA) section. The ASFIC develops a modulation signal by amplifying an audio signal from the microphone, keypad, or handset. The synthesizer section generates a radio frequency carrier signal upon which the transmitter portion of the radio operates. The radio frequency carrier signal generated by the synthesizer section is frequency modulated in the synthesizer section by the modulation signal output from the ASFIC.

The frequency modulated output signal from the synthesizer section is amplified to the required 12-Watt or 30-Watt power level by the power amplifier (PA) section. The output of the PA section passes through the antenna switch and is radiated by the vehicle antenna or fixed-station antenna.

The controller section of the radio contains a microprocessor that controls the radio in accordance with its built in programming as well as commands input manually by the radio operator. The radio operator inputs manual commands to the controller section using the pushbuttons and other controls located on the control head. In addition to its controlling functions, the controller section provides audio amplification of the audio output signal in the receiver function. It also contains squelch detect circuitry based on a buffered discriminator signal from the Zero Intermediate Frequency Integrated Circuit (ZIF IC).

The operator interface function of the radio consists of: a microphone or the microphone portion of a telephone handset; a telephone keypad if used; the pushbuttons and other controls on the control head; and the digital and graphics displays on the control head. The pushbuttons and other controls on the control head provide digital commands to the controller section, and in some instances, hardwired commands to controlled circuits. The digital and graphics displays receive display data from the controller section. The control head contains its own microprocessor, which communicates with the controller section of the radio via an SB9600 serial digital data bus.

The DC power control and regulation function regulates and distributes to the various sections of the radio, DC power from the vehicle battery or fixed station power supply.

Receiver Detailed Functional Description

The portion of the receiver function that is not part of the controller section of the radio is composed of three sections: receiver front end; receiver IF, and receiver back end.

Receiver Front End (All Kits)

The following discussion is based on the schematic diagram for the receiver front end section on page 37. The received RF signal (RX_IN) from the antenna switch in the PA section of the radio enters the first bandpass filter FL6250. The first bandpass filter has three poles, a 938-MHz center frequency, a 6-MHz wide passband, and a 45-dB ultimate rejection for frequencies outside the passband.

After the first bandpass filter, the received RF signal goes to a pair of hot carrier limiting diodes (CR6250). The hot carrier diodes limit strong signals to prevent them from over driving and damaging RF preamplifier Q6271.

The main purpose of RF preamplifier Q6271 is to set the noise figure of the receiver. Q6271 is actively biased through Q6272. During transmit, the RF preamplifier is shut off by the K9.1 line via switch Q6250 and bias transistor Q6272. After the signal leaves the RF preamplifier, it enters second bandpass filter FL6251, which is identical to FL6250.

When the RF signal leaves the second bandpass filter, it goes into mixer U6251. The mixer is the double balanced active Gallium Arsenide type. The RF signal is applied to the mixer through balun transformer T6251. The first injection local oscillator is applied to the mixer via balun transformer T6252 and is 73.35 MHz below the RF signal frequency. The bias for the mixer is set by resistors R6285, R6286, and R6287. The IF output signal from the mixer, which is at a frequency of 73.35 MHz, is fed to the receiver IF section as IF_OUT through transformer T6253.

Receiver Intermediate Frequency (IF) (Kits FLF5591A, B, C; FLF5592A, B, C; HUF1190A; HUF1191A)

The following discussion is based on the schematic diagram for the receiver IF section on page 39.

The IF_OUT signal from the receiver front end section enters the receiver IF section as the IF_IN signal. The first circuit in the receiver IF section is a resistive pad (R6376, R6377, R6378, R6392), which stabilizes the impedance presented to the output of the mixer in the receiver front end section. It also stabilizes the impedance presented to the input of the first 73.35-MHz crystal filter, Y6376.

From the resistive pad, the signal passes through to the first 73.35-MHz crystal filter, Y6376 whose surrounding components match it to 50-ohms and to the input of IF amplifier Q6388. A matching network, which follows Q6388, matches the IF amplifier output impedance to the input impedance of the second 73.35-MHz crystal filter, Y6377. Both crystal filters have two-poles and have a bandwidth of 13kHz to accommodate the bandwidth requirements for digital data. Matching elements, which follow the second crystal filter, match the output of the second crystal filter to the input of the receiver back end section. The signal out of the receiver IF section (IF_V_OUT) passes through

connector J6400 and jumper plug J6401 to the input of the receiver back end section.

Receiver IF
(Kits FLF5604A,
FUF5752A, FLF5952A,
FLF5606A)

The following discussion is based on the schematic diagram for the receiver IF section on page 41.

The IF output signal (IF_OUT) from the receiver front end section enters the receiver IF section as IF_IN and passes into three automatic gain control (AGC)/attenuator stages. The first AGC/attenuator stage is formed by diodes CR6251 and CR6253 and the associated circuitry, the second stage by CR6252, CR6254, and the associated circuitry, and the third stage by CR6255, CR6256 and the associated circuitry.

The three attenuators are controlled by the radio signal strength indicator (RSSI) signal, from the zero intermediate frequency integrated circuit (ZIF IC), in the receiver back end section, via a DC shift and integrator circuit formed by two of the operational amplifiers in U6202. For the lowest level IF_IN signals, the attenuator stages attenuate minimally. For the highest level signals, they attenuate approximately 25dB per stage. The attenuator stages are designed for minimum VSWR, which means that for any level of operation they present a matched port to the surrounding circuitry.

The principle of operation for the attenuator stages, taking the first stage as an example, is the followings: The main components in the attenuator are the two diodes, CR6251 and CR6253. The attenuator is biased by two lines, a constant +5V line, connected to the anode of diode CR6253, and a control line driven by the RSSI signal via the operational amplifiers in U6202.

For a high signal level, the attenuation is at maximum value because the control line is at 0V, which causes CR6251 to be zero biased while CR6253 is maximum biased. This makes the IF signal flow to ground through R6366, C6367 (which acts as a DC block), CR6253, and C6372 (which is also a DC block). The input signal sees a 50-ohm match, which is roughly the sum of the impedances formed by the above mentioned components.

For low signal levels, the attenuation is at minimum value because the control line is at +5V and CR6251 is maximum biased while CR6253 is zero biased. The DC return for the control line is through R6368 and R6370. The large values (470K) of these two resistors makes them also function as RF blocks.

The control line is driven by the RSSI signal line from the ZIF IC in the receiver back end section. The RSSI signal is amplified and DC shifted through one of the operational amplifiers of U6202 and the associated circuitry formed by resistors R6342 through R6345. This then passes through the inverting integrator formed by another operational amplifier of U6202 and C6362, R6358, R6359, R6360 and R6361. The result is that for the lowest RSSI voltage, the control line is +5V and for the highest RSSI voltage, the control line is 0V.

The inherent insertion loss of these attenuators ensures that a good match is presented to the output of the front-end mixer.

Receiver Back End (All Kits)

The third attenuator stage formed by CR6255 and CR6256 is optional and is bypassed by R6357 with C6366 and R6350 not being placed.

The following discussion is based on the schematic diagram for the receiver back end section: page 43 for kits FLF5591A, B, C and FLF5592A, B, C; page 45 for kits FLF5604A, FUF5752A, FLF5952A, and FLF5606A; and page 47 for kits HUF1190A and HUF1191A. From the output of the receiver IF section, the IF signal (IF_IN) enters IF amplifier Q6203. A pair of hot carrier limiter diodes (CR6203) at the base of the IF amplifier protect U6201, the Zero Intermediate Frequency Integrated Circuit (ZIF IC), from strong signal overloading.

With kits FLF5591A, B, C and FLF5592A, B, C, the output of IF amplifier Q6203 is fed to a shunt pin diode attenuator, CR6203. The attenuation provided by the pin diode attenuator is a function of the signal level detected by the internal automatic gain control (AGC) circuit in the ZIF IC. As the RF level increases, the attenuation increases. This ensures that the ZIF IC, whose dynamic range is much less than that of the radio, is not over driven by strong signals, causing distortion in the detected signal.

With kits FLF5604A, FUF5752A, FLF5952A, and FLF5606A, this attenuation function is performed by the attenuator stages in the receiver IF section and this ACG mechanism in the receiver back end section is bypassed. To do this, shorting resistor R6224 is mounted bypassing CR6203, which is not mounted, an additional shorting resistor is placed on the pads of L6208 instead of the 1 microHenry inductor, and CR6204 is not placed.

At the output of Q6203, there is a notch filter, for the third harmonic of 73.35 MHz, made up of components C6249 and inductor L6207. Transistor Q6201 and varactor diode CR6201 form the second local oscillator (LO). The LO operates as a voltage controlled oscillator (VCO), which is controlled by the ZIF IC.

The ZIF IC is a down converter, a filter, a limiter, and an FM demodulator. The IF signal going into the ZIF IC at 73.35MHz is down converted, filtered, limited, and demodulated. Demodulated audio comes out of the ZIF IC from pin 28 and is fed to the ASFIC audio signal filtering IC, which is part of the controller section of the radio.

In addition to the audio output signal, the receiver section provides a squelch signal output, which also is processed and used by the controller section of the radio to mute the receiver output during periods of no signal reception.

Refer to the discussion under the title *Receive Audio Circuits*, which is located in the *Controller Section Theory of Operation* portion in Volume 1 of this service manual.

Transmitter Detailed Functional Description

The transmitter function of the radio is distributed between the controller, the synthesizer, and the transmitter power amplifier (PA) sections. This is shown on the overall functional block diagram for the radio, Figure 1. The portion of the transmitter function physically located in the controller section is described in the *Controller Section Theory of Operation* located in Volume 1 of this service manual. That portion includes the audio circuits that filter, amplify, and otherwise process the audio signal from the microphone and/or telephone handset. The portion of the transmitter function located in the synthesizer section of the radio is described in the *Synthesizer Detailed Functional Description* in this volume of the service manual. The synthesizer section of the transmitter receives the amplified and processed audio signal from the controller section and produces a frequency-modulated radio frequency carrier (injection) signal, which is input to the transmitter power amplifier (PA) section.

The remaining part of the transmitter function of the radio is located in the PA section. The following discussion covers the part of the transmitter function that is physically located in the PA section.

There are two different configurations of the PA section; one for the 12-Watt radio, and the other for the 30-Watt radio.

12-Watt Power Amplifier (Kits FLF5591A, B, C; FLF5604A, FLF5952A; HUF1190A)

The following discussion is based on the schematic diagram for the 12-Watt power amplifier (PA), on page 49 for kits FLF5591A, B, C, FLF5604A, and HUF1190A and on page 51 for kit FLF5952A.

The power amplifier (PA) is a radio frequency (rf) power amplifier, which amplifies the output from the injection string (TX_INJ) to an RF output power level of 12 Watts. It consists of a driver stage Q6501, followed by a power amplifier module U6501.

In kits FLF5591A, B, C and FLF5604A, the second and third stages of U6501 operate directly from the A+ supply voltage received from connector J6502 via current sense resistor R6520. To protect the input stage from voltage transients on the A+ line, the first stage of U6501 is operated from the keyed K9.1 voltage, which is provided by the controller section of the radio.

In kit FLF5952A, two DC supply inputs for U6501 (+DCISUP and +DCISUPP) are obtained directly from the A+ line via R6520. The transmit enable input (+DCBIAS) is obtained from the A+ line via R6520 and switch U6502, which is controlled by the keyed K9.1 voltage.

The rf drive, which is routed into transistor Q6501, is controlled from Q6506 via the PA control line. A rising control voltage on the PA control line causes a rising collector voltage on Q6501. This causes more power to be delivered into the next stage. Conversely, a decreasing control line voltage decreases the power delivered into the next stage. By controlling the drive power to U6501 and the following stages in the power amplifier lineup, automatic level control (ALC) is accomplished, which regulates the output power of the transmitter.

The output of U6501 goes to the antenna switch. The antenna switch is switched by the keyed 9.1 voltage. In the transmit mode, the keyed K9.1 voltage is high. In kits FLF5591A, B, C and FLF5604A, the high K9.1 voltage turns on diodes CR6502, CR6503, and CR7504. When CR6502 is turned on, it forms a low impedance to the RF transmit path and allows the signal to pass through. Diode CR6503 forms a low impedance that is transformed to an open circuit through a quarter wavelength transmission line. This prevents transmitter power from being delivered into the receiver. Diode CR7504 is also turned on in the transmit mode, further isolating the receiver port from transmitter energy. In the receive mode, all these diodes are off. The off capacitance of CR6502 is tuned by L6508 to form a high impedance looking into the transmitter. Therefore, energy coming in the receive mode is channeled to the RX port.

In kit FLF5952A, the antenna switch has only two diodes (CR6502 and CR6504). The two diodes are forward biased by the K9.1 voltage in transmit mode and zero biased in receive mode.

Harmonics of the transmitter are attenuated by the harmonic filter. In kits FLF5591A, B, C and FLF5604A, the harmonic filter is formed by two inductors (L6512 and L6513) and six capacitors (C6539, C6540, C6542, C6543, C6544, C6546). This network forms a low-pass filter to attenuate harmonic energy of the transmitter to an acceptable level. In kit FLF5952A, there are only three capacitors (C6543, C6544, and C6546).

A forward power detector follows the harmonic filter. This forward power detector is a microstrip printed circuit, which couples a small amount of the forward power going out of the radio to diode CR6506 where it is rectified. This rectified signal forms a voltage that is proportional to forward power out of the radio. A power control circuit in the controller section of the radio holds this voltage constant, which ensures the forward power out of the radio is held constant.

In the PA compartment, 50k thermistor R6519 senses the temperature in the area of the power module. The resultant signal is fed back to the power control circuit to protect the power amplifier against over-temperature conditions. Resistor R6520, in series with the A+ line supply, feeds voltage to the power module. The voltage across R6520 is sensed and the resultant two inputs are channeled to the power control circuit. The power control circuit senses the voltage drop across this resistor, which is determined by the magnitude of the drain current in U6501. It uses this as a limit mechanism whereby the power control circuit limits the magnitude of current that can be drawn by U6501. This protects the device from excessive power dissipation.

Reverse polarity protection for the transmitter is provided by diode CR6508. The cathode is soldered to the A+ line while the anode is shorted to the chassis via a spring. In kits FLF5604A and FLF5952A, the diode is a surface mount device and the anode is soldered to the printed circuit board ground plane. Under reverse polarity conditions to the radio, this diode conducts and protects the radio from damage. This diode also provides transient over-voltage protection by breaking down when the supply voltage to the radio exceeds 24 volts.

30-Watt Power Amplifier (Kits FLF5592A, B, C; FUF5752A; FLF5606A; HUF1191A)

The following discussion is based on the schematic diagram for the 30-Watt power amplifier (PA) on page 53 for kits FLF5592A, B, C, FUF5752A, and HUF1191A, and on page 55 for kit FLF5606A.

The power amplifier (PA) is a radio frequency (rf) power amplifier, which amplifies the output from the injection string (TX_INJ) to an RF output power level of 12 Watts. It consists of a driver stage Q6501, followed by a power amplifier module U6501.

In kits FLF5592A, B, C, FUF5752A, and HUF1191A, the second and third stages of U6501 operate directly from the A+ supply voltage received from connector J6502 via current sense resistor R6520. To protect the input stage from voltage transients on the A+ line, the first stage of U6501 is operated from the keyed K9.1 voltage, which is provided by the controller section of the radio.

In kit FLF5952A, two DC supply inputs for U6501 (+DCISUP and +DCISUPP) are obtained directly from the A+ line via R6520. The transmit enable input (+DCBIAS) is obtained from the A+ line via R6520 and switch U6502, which is controlled by the keyed K9.1 voltage.

The rf drive, which is routed into transistor Q6501, is controlled from Q6506 via the PA control line. A rising control voltage on the PA control line causes a rising collector voltage on Q6501. This causes more power to be delivered into the next stage. Conversely, a decreasing control line voltage decreases the power delivered into the next stage. By controlling the drive power to U6501 and the following stages in the power amplifier lineup, automatic level control (ALC) is accomplished, which regulates the output power of the transmitter.

The output of U6501 goes to an additional power amplifier stage (Q6505) whose output is coupled to the antenna switch via a matching hybrid (H6501). Transistor Q6505 raises the 12-Watt RF power output level of U6501 to the required 30 Watts. Matching hybrid H6501 ensures the proper collector load for Q6505 and provides correct impedance matching between the output of Q6505 and the antenna switch.

The antenna switch is switched by the keyed 9.1 voltage. In the transmit mode, this keyed 9.1 voltage is high turning on diodes CR6502, CR6503, and CR1. When CR6502 is turned on, it forms a low impedance to the RF transmit path and allows the signal to pass through. Diode CR1 forms a low impedance that is transformed up to an open circuit through a quarter wavelength transmission line. This prevents transmitter power from being delivered into the receiver. Diode CR6503 is also turned on in the transmit mode further isolating the receiver port from transmitter energy.

In the receive mode all the diodes are off. The off capacitance of CR6502 is tuned by L6508 to form a high impedance looking into the transmitter. Therefore, energy coming in the receive mode is channeled to the RX port. Harmonics of the transmitter are attenuated by the harmonic filter. The harmonic filter is formed by components L2, L3, and L4, and capacitors C3, C5, C7, and C9. This network forms a low-pass filter to attenuate harmonic energy of the transmitter to an acceptable level.

A forward power detector follows the harmonic filter. This forward power detector is a microstrip printed circuit, which couples a small amount of the forward power going out of the radio to diode CR2 where it is rectified. This rectified signal forms a voltage that is proportional to forward power out of the radio. A power control circuit in the controller section of the radio holds this voltage constant, which ensures the forward power out of the radio is held constant.

In the PA compartment, 50k thermistor R6519 senses the temperature in the area of the power module. The resultant signal is fed back to the power control circuit, in the controller section of the radio, which protects U6501 by reducing the power output in the event of an over-temperature condition. Resistor R6520, in series with the A+ line supply, feeds voltage to the power transistor. The voltage across R6520 is sensed and the resultant two inputs are channeled to the power control circuit. The power control circuit senses the voltage drop across this resistor, which is determined by the magnitude of the drain current in Q6505. It uses this as a limit mechanism whereby the power control circuit limits the magnitude of current that can be drawn by Q6505. This protects the device from excessive power dissipation.

Reverse polarity protection for the transmitter is provided by diode CR6508. The cathode is soldered to the A+ line while the anode is shorted to the chassis via a spring. In kits FLF5606A and FUF5752A, the diode is a surface mount device and the anode is soldered to the printed circuit board ground plane. Under reverse polarity conditions to the radio, this diode conducts and protects the radio from damage. This diode also provides transient over-voltage protection by breaking down when the supply voltage to the radio exceeds 24 volts.

Synthesizer Detailed Functional Description (All Kits)

The synthesizer section of the radio generates the first conversion local oscillator signal and the second conversion reference oscillator for the receiver portion of the radio. It also generates the transmitter rf carrier signal, which is frequency modulated by the amplified and processed audio signal from the output of the audio signal filter IC (ASFIC) in the controller section of the radio. The frequency modulated transmitter rf carrier signal is amplified by the transmitter PA section of the radio.

The following discussion is based on the schematic diagram for the synthesizer section on page 57. The synthesizer section consists of a pendulum reference oscillator (U6704) and a phase locked loop (PLL), which is made up of a fractional-N synthesizer integrated circuit (IC), (U6702), a loop filter, two voltage controlled oscillators (VCO) (U6711 and U6712), a buffer amplifier (U6703), and a feedback amplifier (Q6710).

The pendulum reference oscillator (U6704) contains a temperature compensated crystal, which has an oscillation frequency of 16.8 MHz. The output of the oscillator (pin 10 of U6704) is applied to pin 14 (XTAL1) of U6702 via C6717 and R6701. VCOs U6711 and U6712 are varactor tuned. The VCO frequencies are controlled by the voltage applied to pin 10 of U6711 and U6712. This control voltage ranges from about 2.5 to 10.5Vdc. A small control voltage produces a lower frequency and a large control voltage produces a high frequency, respectively.

The RX VCO U6712 (861 - 867 MHz frequency range) provides the first LO injection frequency for the receiver, which is 73.35 MHz below the carrier frequency. The RX VCO is selected by setting pin 7 high on U6712.

The TX VCO U6711 (896 - 941 MHz frequency range) provides the transmit frequency in conventional mode and the transmit frequencies in talk around mode. The Tx VCO is selected by setting pin 8 high on U6711.

The buffer stage (U6703) and the feedback amplifier (Q6710) provide the necessary gain and isolation for the phase locked loop.

The fractional-N synthesizer IC, U6702, consists of a prescaler, a programmable loop divider, control divider logic, a phase detector, a charge pump, an A/D converter for low frequency digital modulation, a balance attenuator to balance the high and low frequency analog modulation, a 13V positive voltage multiplier, a serial interface for control, and a super filter for the regulated 9.3 volts. Q6709 is used as a current amplifier for the super filter. The output voltage of the super filter (collector of Q6709) drops from 9.3V to about 8.5V. This filtered 8.5Vdc supplies the voltage for the VCOs (U6711 and U6712), the TX/RX VCO switches (U6708 and U6710), the feedback amplifier (Q6710), and the synthesizer charge pump resistor network (R6705, R6706 and R6755).

The synthesizer supply voltage is provided by the 5V regulator (U6705). The 2.1 MHz reference signal (pin 10 of U6702) is generated by dividing down the signal of the reference oscillator U6704 after it is applied to pin 14 of U6702.

In order to generate a high voltage that supplies the charge pump output stage at pin VCP (pin 36 of U6702), 13 V is generated at pin 1 of CR6701 by the positive voltage multiplier circuitry (CR6701). This voltage multiplier is basically a diode capacitor network driven by two 1.05 Mhz, 180 degrees out of phase signals (pins 8 and 9 of U6702).

The serial interface (SRL) is connected to the controller section of the radio via the data line (pin 2 of U6702), clock line (pin 3 of U6702), and chip enable line (pin 4 of U6702). Proper enabling of these lines allows the controller section to load the fractional-N synthesizer IC.

The output of the VCO (pin 4 of U6712 or pin 6 of U6711) is fed into the buffer input port (pin 1) of U6703 through an attenuator network (R6707, R6708, R6709). The output of the buffer, pin 5 of U6703, is applied to the input of the feedback amplifier (Q6710) through an attenuator network (R6749, R6750, R6751). To close the synthesizer loop, the output of Q6710 is connected to the PREIN port (pin 21) of synthesizer U6702. The buffer output (pin 5 of U6703) also provides signal for the receiver LO injection and the transmit injection string circuit. The charge pump current is present at pin 31 of U6702.

The loop filter (which consists of R6702, R6703, R6704, C6732, C6734, C6735, C6736, C6737, C6785, C6786, C6817, C6818) transforms this current into a voltage. That voltage is applied to pin 8 of the TX VCO (U6711) or pins 7 of RX VCO (U6712), which alters the output frequency.

The phase locked loop is frequency modulated by the transmit audio signal from the controller section. To accomplish this, the audio signal from the controller section is applied to pin 5 of fractional-N synthesizer IC U6702.

An A/D converter in the fractional-N synthesizer IC converts the analog modulating signal into a digital code, which is applied to a loop divider. This causes the carrier frequency to deviate. A balanced attenuator is used to adjust the VCO's deviation sensitivity to high frequency modulating signals. The output of the balanced attenuator is present at the MOD OUT port (pin 30 of U6702).

The transmit injection string in the synthesizer consists of two amplifier stages (Q6702 and Q6704) whose main purpose is to maintain a constant output to drive the RF power amplifier and to provide isolation. The two stages (Q6704 and Q6702) are actively biased through Q6701 and Q6703. The TX injection string is on only during the transmit mode with K 9.1V.

Controller Detailed Functional Description

The theory of operation for the controller section of the radio is located in Volume 1 of this service manual.

Dc Power Control and Regulation Detailed Functional Description

The theory of operation for the dc power control and regulation section of the radio is located in Volume 1 of this service manual.

NOTES

Troubleshooting and Repair

3

This chapter is divided into two sections: 3-1, Troubleshooting; and 3-2 Repair.

Section 3-1 provides troubleshooting charts for the receiver, synthesizer, and power amplifier sections of the radio. The receiver, synthesizer, and power amplifier sections of the radio are unique for each frequency range. (Troubleshooting Charts for the overall radio and for the sections of the radio that are common in design for all frequency ranges (i.e., controller, power control, and control heads) are provided in Volume 1 of this Service Manual, Motorola Publication Number 68P81083C20.)

Section 3-2 provides a replacement procedure for the RF power Output transistor (Q6505) used only in the 30-Watt version of the radio.

Troubleshooting information and troubleshooting Charts related to the SECURENET Option for the radio are located in the SECURENET Option Service Manual, Motorola Publication 68P81083C25.

Option Service Manual, Motorola Publication 68P81083C25.

Section 3-1 - Troubleshooting (All Kits)

This section contains the following troubleshooting charts for the receiver, synthesizer, and transmitter sections of the radio.

NOTE: Troubleshooting charts 1-1 through 1-13 are located in Volume 1 of this Service Manual, Motorola Publication 68P81083C20, because these troubleshooting charts are common to all models of the radio.

- **Receiver:**

- Troubleshooting Chart 2d-1, Receiver Front End - Page 25
- Troubleshooting Chart 2d-2, Receiver IF and Receiver Back End - Page 26

- **Synthesizer:**

- Troubleshooting Chart 2d-3, Synthesizer Deviation - Page 27

- Troubleshooting Chart 2d-4, Synthesizer Pendulum Oscillator - Page 28
- Troubleshooting Chart 2d-5, Synthesizer Main - Page 29
- Troubleshooting Chart 2d-6, Synthesizer No Transmitter Injection Signal - Page 30
- **Power Amplifiers:**
 - Troubleshooting Chart 2d-7, 12-Watt Power Amplifier - Page 31
 - Troubleshooting Chart 2d-8, 30-Watt Power Amplifier - Page 32

Section 3-2 - Repair

This section provides a replacement procedure for Q6505, the rf power output transistor in the 30-Watt power amplifier.

Replacement of Transistor Q6505

To replace Q6505, proceed as follows:

Tools and Materials Required

Before proceeding, ensure that the following tools and materials are on hand:

- Alcohol (isopropyl)
- High temperature solder, SN96AG04 composition, Motorola Part No 1180433L04
- Hot air gun (600 degrees maximum temperature)
- Low lint wipers or rag
- Soldering station including a soldering iron with chisel-style tip which is approximately 1/8-inch in size
- Solder flux
- Solder wick
- Stiff brush, natural bristles approximately 1-cm high and 1-cm wide
- Thermal compound, Motorola Part No. 111022D23
- Transistor assembly tool, Motorola Part No. 0186126F01, Motorola kit No. FLN9037A
- Thermal pad for heatsink block B6501, Motorola part number 7508184K01

Disassembly of Radio

1. Remove transceiver board from radio chassis following procedure provided in Volume 1 of this service manual, Motorola Publication 68P81083C20.
2. After transceiver board is removed from radio chassis, clean off thermal paste from all surfaces that have thermal paste on them using low lint wipers or rag.

Removing Faulty Transistor

1. Before removing faulty transistor, observe carefully how flange capacitors C6567 and C6568 are mounted. This will help you later in mounting new capacitors.
2. Set hot air gun for medium temperature and low air speed. This will ensure that other components in vicinity of Q6505 will not get dislodged and moved accidentally.
3. Train hot air gun on flanges of transistor. After a few moments, the solder holding flanges will reflow enabling transistor and flange capacitors C6567 and C6568 to be lifted off transceiver board together.

Preparing Transceiver Board for New Transistor

1. Using solder wick, isopropyl alcohol, and stiff bristle brush, remove excess solder and clean pads on transceiver board where transistor was soldered.
2. Place transceiver board, with its heavy side up, on transistor assembly tool. Heavy side is side with DC-power and antenna connectors. Make certain that all four guide pins on transistor assembly tool are engaged into their corresponding holes in transceiver board.
3. Identify the six pads on transceiver board corresponding to the six flanges on transistor. The four corner pads are ground; the middle pad towards antenna connector is the transistor collector; and the opposite middle pad is the transistor emitter.

NOTE: In next step, be certain to tin transistor pads and fill via holes with high temperature solder, composition SN96PB04.

4. Using solder iron, carefully tin each of the six pads so that they are covered with a thin coat of solder and all via holes are filled.

Positioning New Transistor

1. Place a small spot of flux on each of the six transceiver-board pads to which the flanges of transistor are to be soldered.
2. Insert the narrow-diameter side of a spacer, Motorola Part Number 4380545K01, into each of the two transistor mounting holes in transceiver board.
3. Ensure that new transistor is correct replacement type by verifying that M25C20 is printed on transistor face.

NOTE: Collector flange of transistor is the one with its corner cut off.

4. Position new transistor onto transceiver board with collector flange oriented towards antenna connector. Ensure that transistor is sitting snug on transceiver board with all six flanges flat on their corresponding transceiver-board pads.
5. Lower arm of Distaco clamp on transistor assembly tool. Then lock clamp with its lever to clamp transistor in place on transceiver board.

Soldering Transistor

1. Place a small spot of flux on each of the six transistor flanges.
2. Solder each transistor flange to transceiver board as follows:
 1. - Set soldering iron temperature to approximately 400 degrees Centigrade.
 2. - Melt a small mound of solder onto flat face of soldering iron.



Caution

In next step, to avoid damage to transistor and capacitors, ensure that each soldering operation takes *no more* than three to four seconds to accomplish.

3. Press face of soldering iron firmly to flange for *no more* than three to four seconds.
4. Inspect transistor flange carefully to ensure it is soldered securely, and that it is not shorted to any of the other flanges or to the transistor heat sink.

Installing Flange Capacitors C6567 and C6568.

NOTE: Capacitors C6567 and C6568 get mounted flat on transistor collector and ground flanges with non-solderable edge flush against transistor body. Each capacitor is attached by soldering its outside solderable edge to one of the transistor ground flanges and its inside solderable edge to transistor collector flange. There must be a gap of approximately 2 millimeters between the two capacitors (i.e., room to insert a chisel style solder iron tip) to ensure that good solder joints can be made between capacitor leads and collector flange of transistor.

1. Ensure that both capacitors C6567 and C6568 are correct replacement type by verifying that Motorola Part Number is 2113742B23, value is 12pF, and marking is C1.



Caution

In next two steps, to avoid damage to transistor and capacitors, ensure that soldering operations take *no more* than three to four seconds to accomplish.

2. Solder outside solderable edge of each capacitor to one transistor ground flange, being certain that each capacitor is flat on transistor flange with non-solderable edge flush against transistor body.

3. Place a small drop of flux on transistor collector flange between capacitors. Place chisel style solder iron tip between capacitors and onto collector flange of transistor. Feed in some high temperature solder (SN96PB04) so that inside solderable edges of both capacitors are soldered securely to collector flange of transistor.
4. Examine soldered capacitors. Ensure that they are reasonably flush against transistor body and are not shorting transistor collector flange to transistor heat sink.
5. Examine surrounding components to ensure that none of them have been damaged or displaced.

Reassembly of Radio

1. Examine face of transistor heat sink. Ensure that it is free from burrs and flux, which could prevent a good thermal contact to radio chassis.
2. Spread thermal compound on heat sink of the following components:
 - Transistor Q6505
 - PA module U6501
 - Audio PA module U0203
 - +5V regulator U0500
 - +9.3V voltage regulator U0501
3. Place a new thermal pad, Motorola Part No. 7508184K01, on heat sink block B6501.
4. Install transceiver board into radio chassis following procedure provided in Volume 1 of this service manual, Motorola Publication 68P81083C20.

NOTES

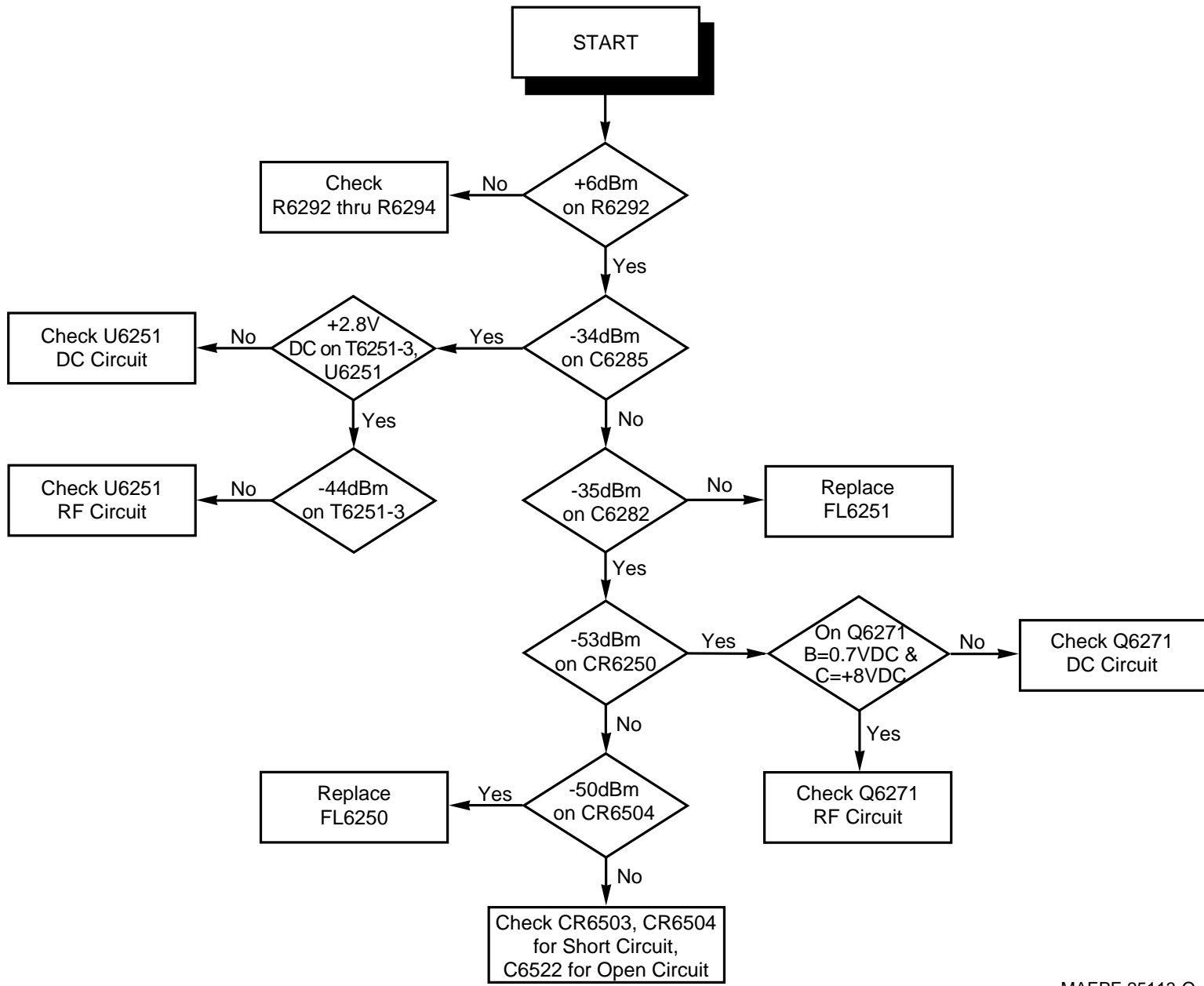

MAEPF-25113-O

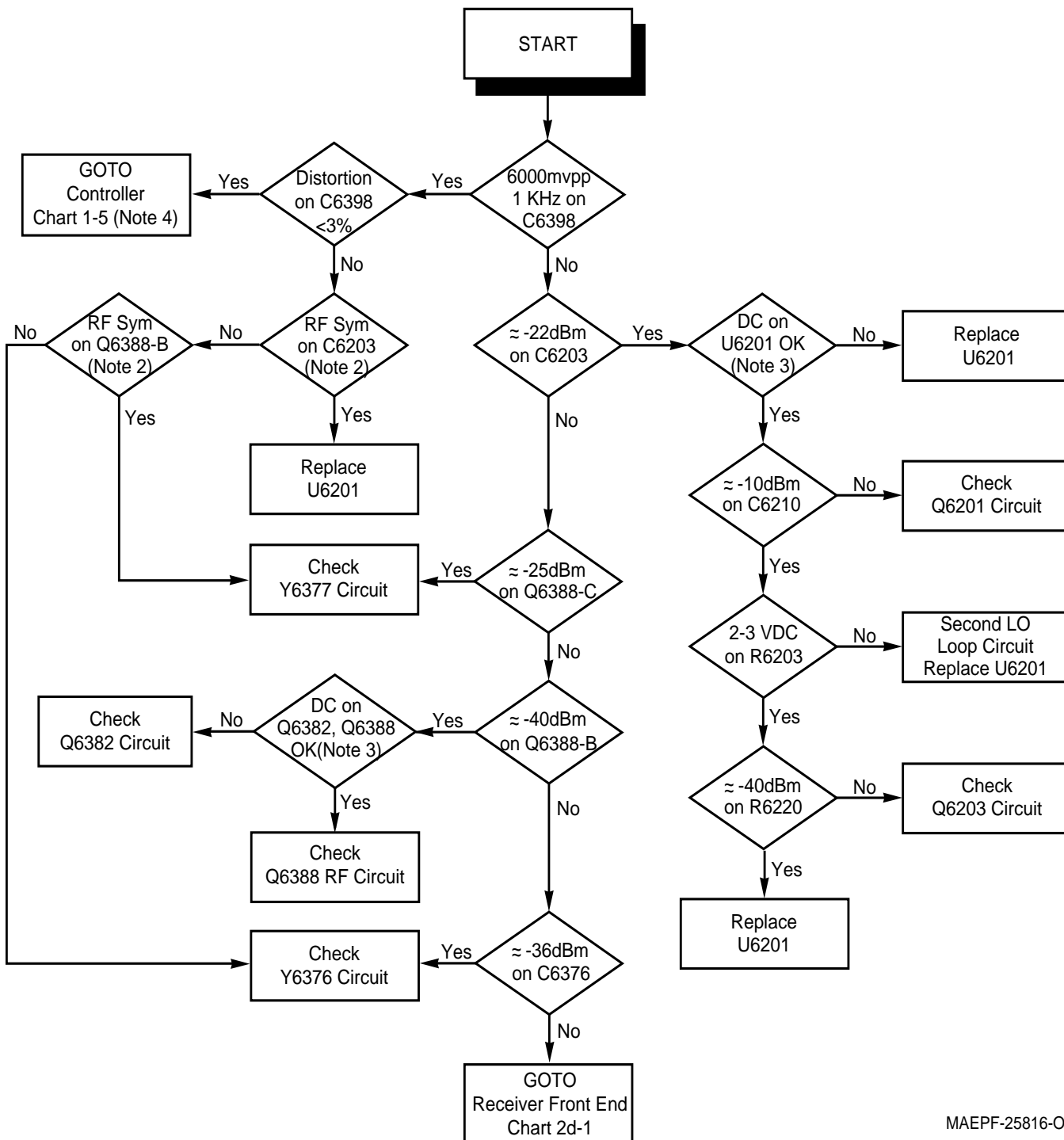

- NOTES: 1. Check distortion with HP8903B using either CCITT, C-MESSAGE, or PSHOMETRIC audio filter.
 2. At $F_0 \pm 3, 6, 9$ KHz (No Modulation) RF Symmetry should be ± 1 dB.
 3. DC Voltages for Q6382, Q6388, and U6201 are:
- | Device | Emitter | Base | Collector |
|--------|---------|------|-----------|
| Q6382 | 6.25 | 5.7 | 1.05 |
| Q6388 | 0.1 | 0.85 | 6.2 |
| U6201 | 1.7 | 2.3 | 3.3 |
4. Chart 1-5 is located in Volume 1 of this service manual.

MAEPF-25816-O

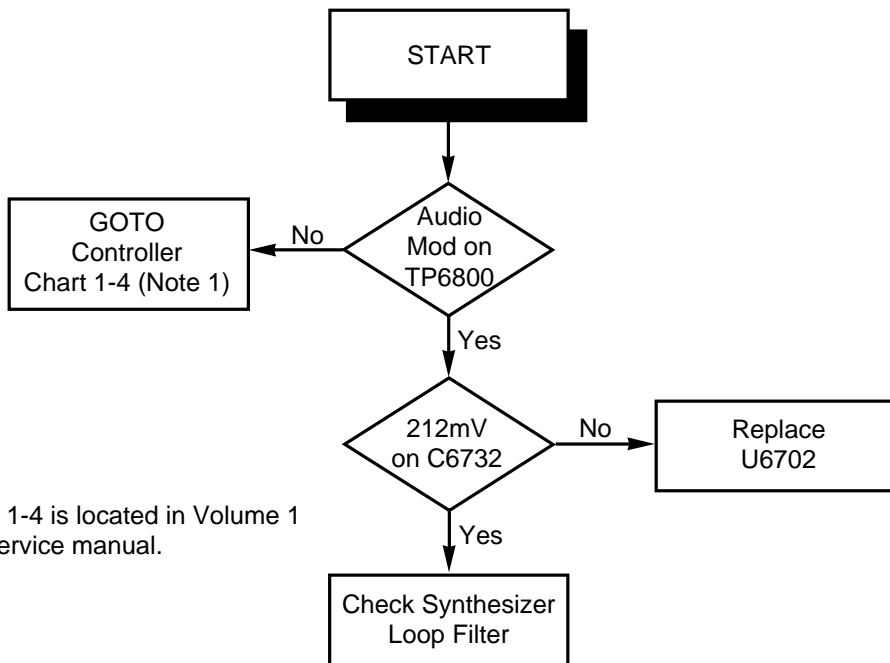

NOTE: 1. Chart 1-4 is located in Volume 1 of this service manual.

MAEPF-25114-A

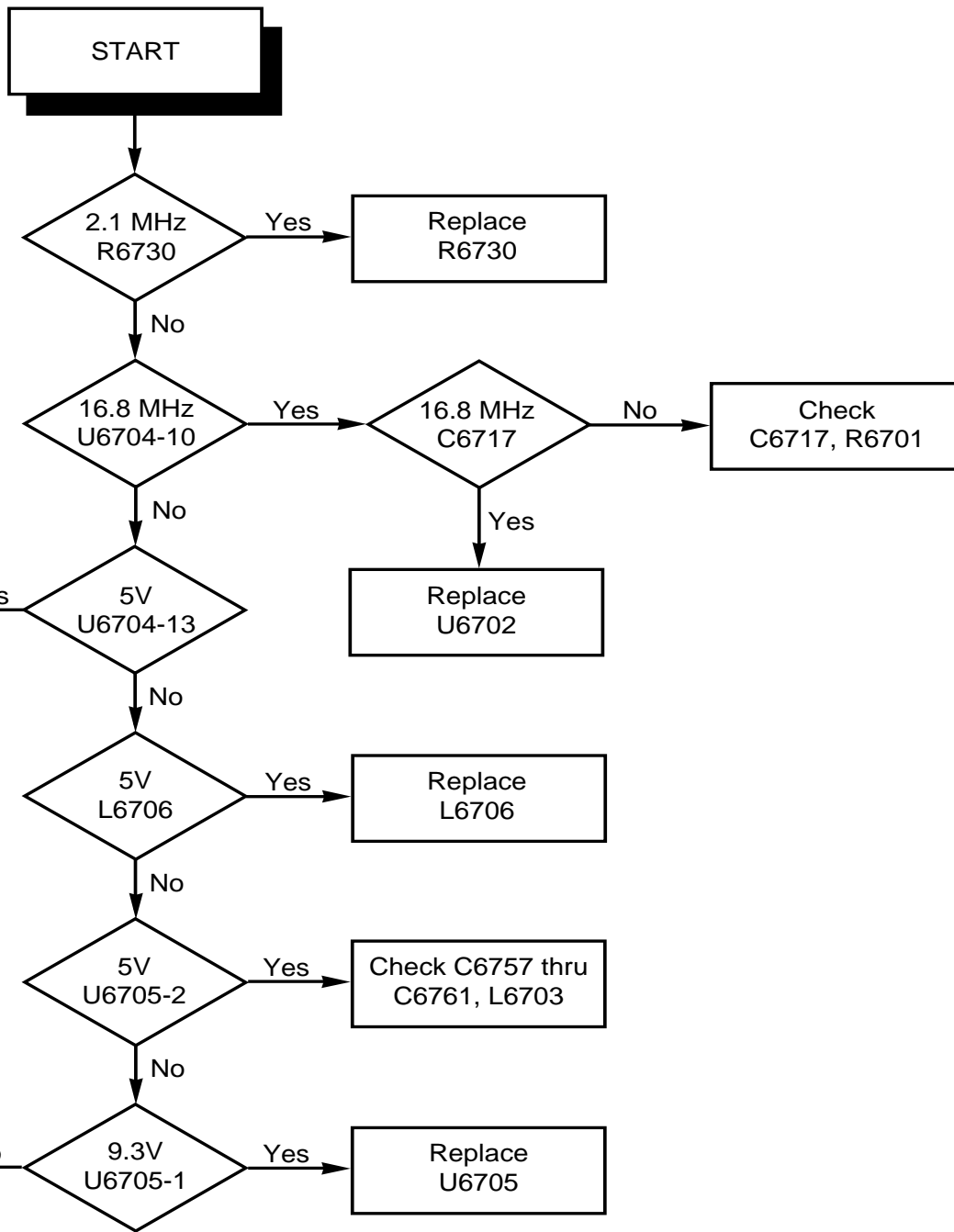

MAEPF-25115-O

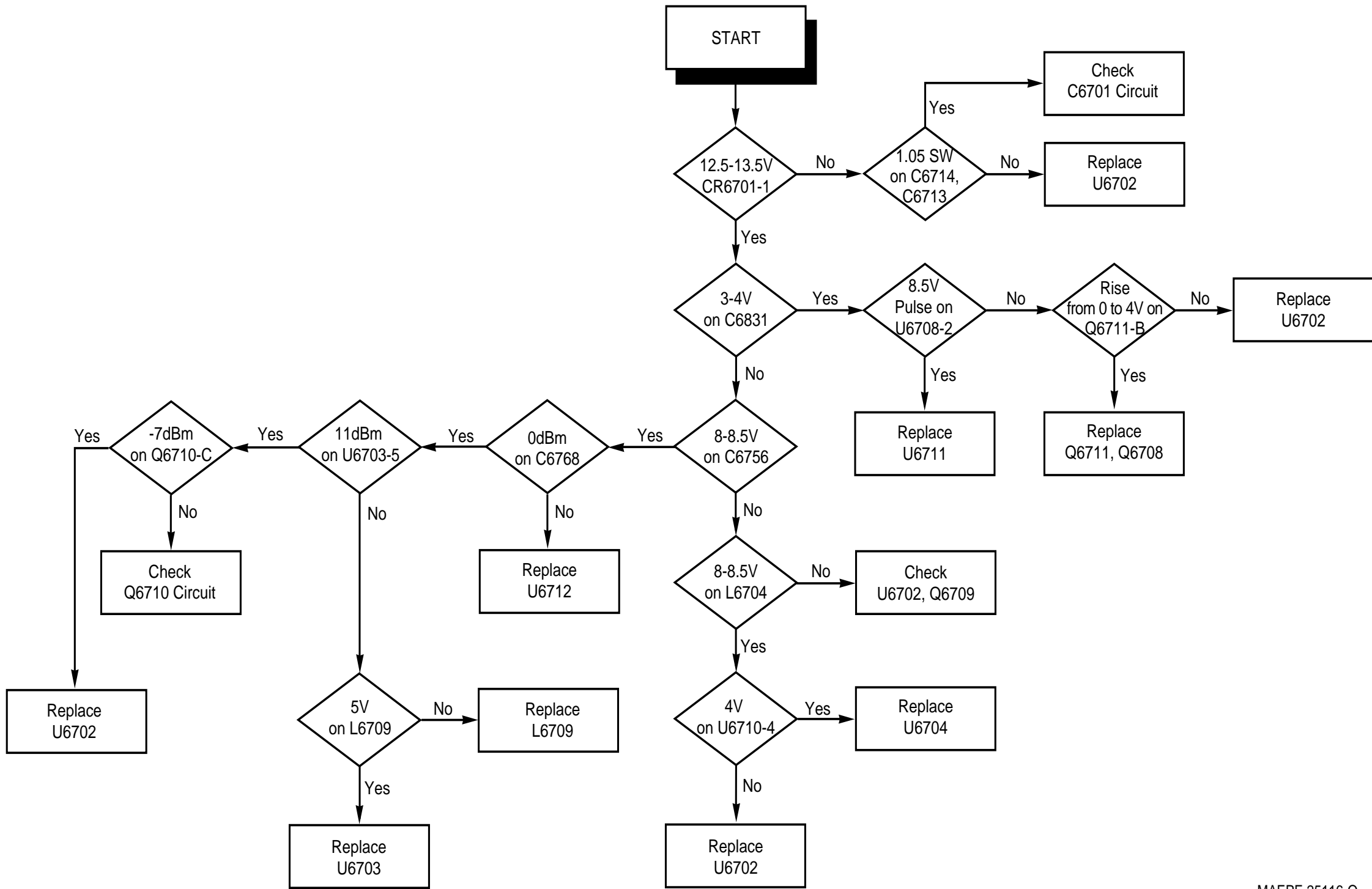

MAEPF-25116-O

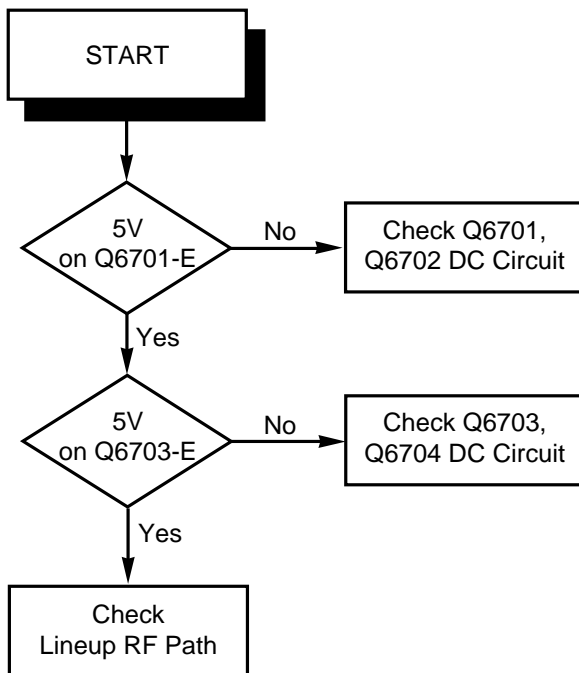

MAEPF-25117-O

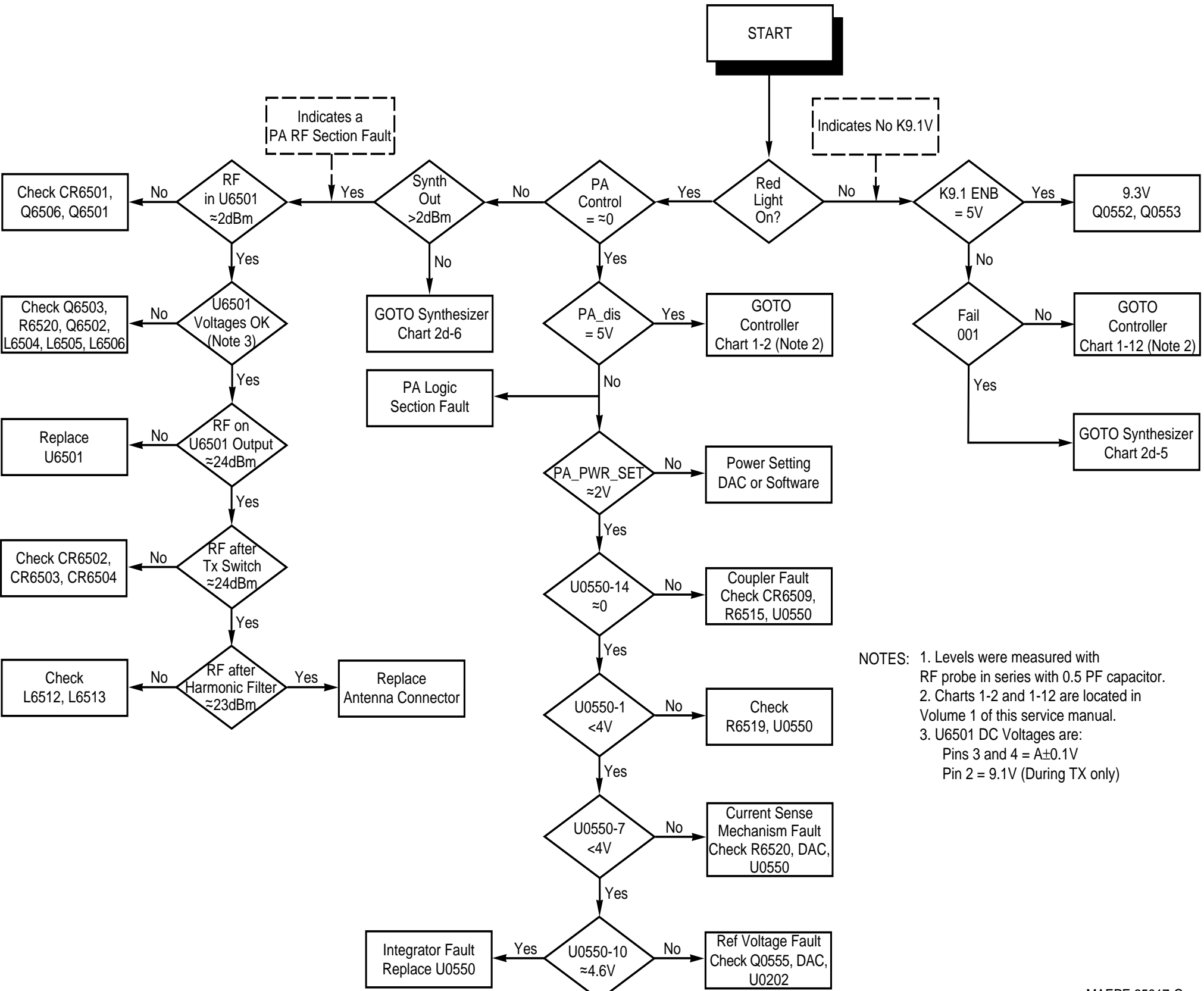

NOTES: 1. Levels were measured with RF probe in series with 0.5 PF capacitor.
 2. Charts 1-2 and 1-12 are located in Volume 1 of this service manual.
 3. U6501 DC Voltages are:
 Pins 3 and 4 = A±0.1V
 Pin 2 = 9.1V (During TX only)

MAEPF-25817-O

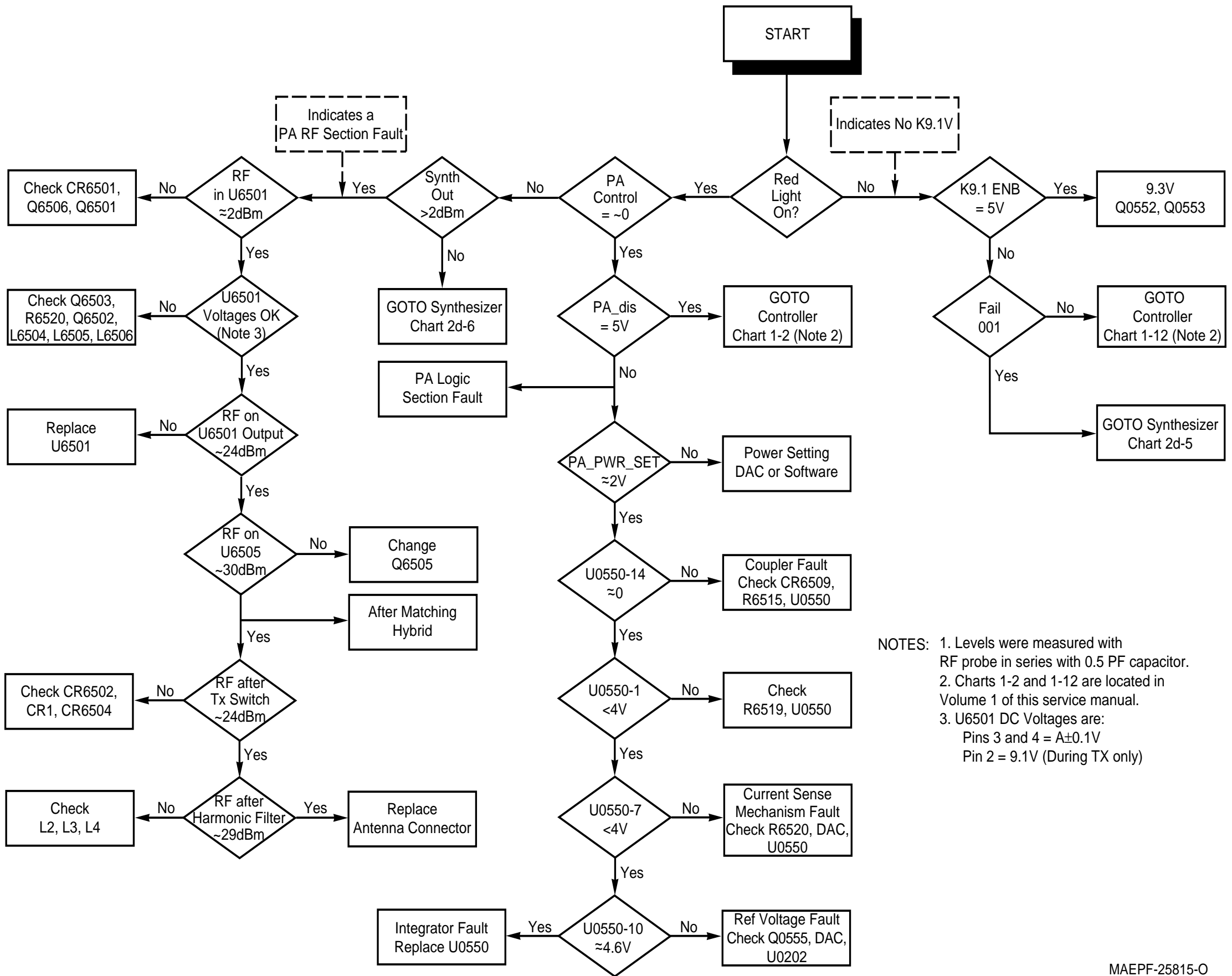

NOTES: 1. Levels were measured with RF probe in series with 0.5 PF capacitor.
 2. Charts 1-2 and 1-12 are located in Volume 1 of this service manual.
 3. U6501 DC Voltages are:
 Pins 3 and 4 = A±0.1V
 Pin 2 = 9.1V (During TX only)

MAEPF-25815-O

Reference Drawings

4

This section contains the reference drawings listed below for the receiver (front end, IF, and back end), transmitter, and synthesizer portions of the radio.

- **Overall Radio:**

- Transceiver Board Section Locations - Page 34
- Schematic Diagram Interconnection List, Table 2 - Page 59

- **Receiver:**

- Receiver Front End Component Locations and Parts List - Page 36
- Receiver Front End Schematic Diagram - Page 37
- Receiver IF Component Locations and Parts List - Pages 38 and 40
- Receiver IF Schematic Diagram - Pages 39 and 41
- Receiver Back End Component Locations and Parts List - Pages 42, 44 and 46
- Receiver Back End Schematic Diagram - Pages 43, 45 and 47

- **Power Amplifiers:**

- 12-Watt Power Amplifier Component Locations and Parts List - Pages 48 and 50
- 12-Watt Power Amplifier Schematic Diagram - Pages 49 and 51
- 30-Watt Power Amplifier Component Locations and Parts List - Pages 52 and 54
- 30-Watt Power Amplifier Schematic Diagram - Pages 53 and 55

- **Synthesizer:**

- Synthesizer Component Locations and Parts List - Page 56
- Synthesizer Schematic Diagram - Page 57

Refer to Volume 1 of this service manual (Motorola Publication 68P81083C20) for reference drawings for the controller, power control, and control head portions of the radio.

Refer to the SECURENET Option service manual (Motorola Publication 68P81083C25) for reference drawings for the secure option for the radio.

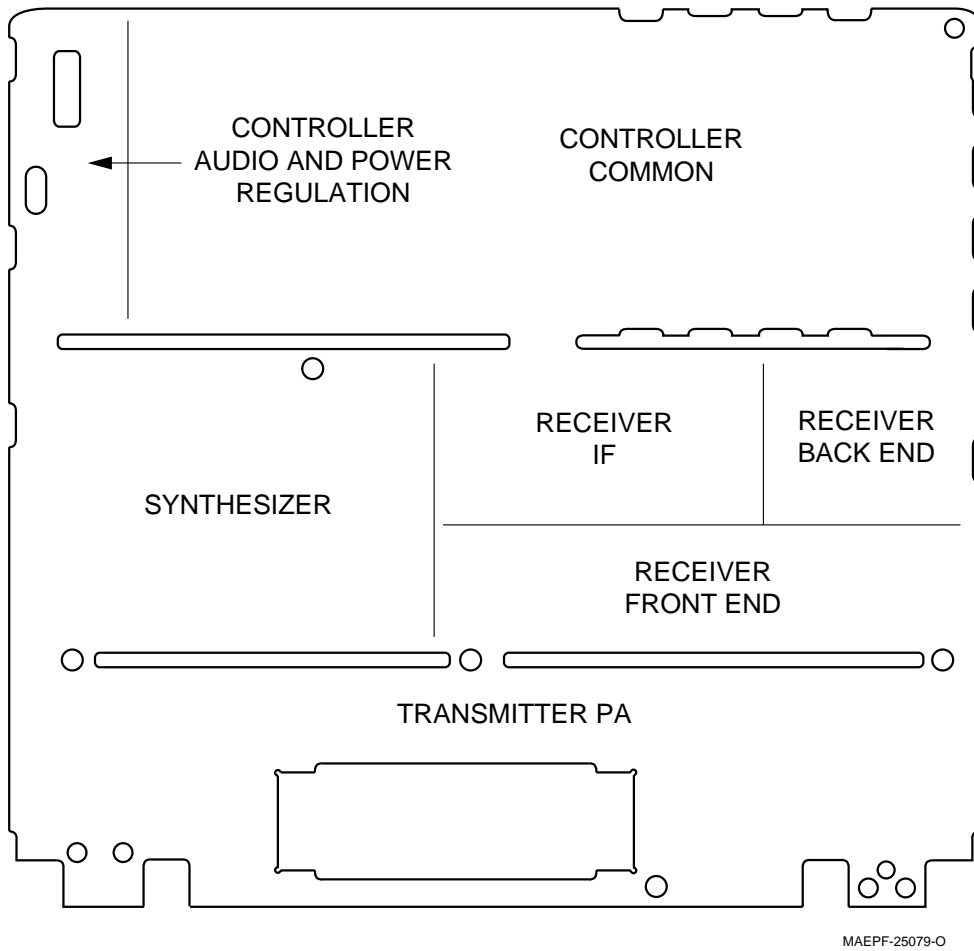
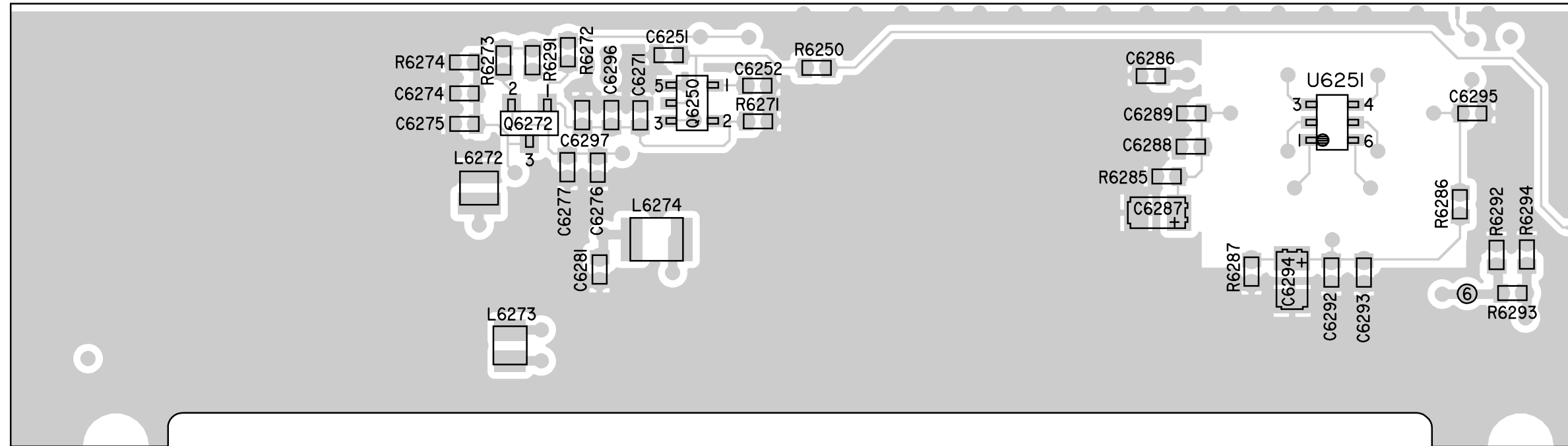

Figure 2 Transceiver Board Section Locations

NOTES

RECEIVER FRONT END COMPONENT LOCATIONS



LIGHT COMPONENTS SIDE

MAEPF-25082-A

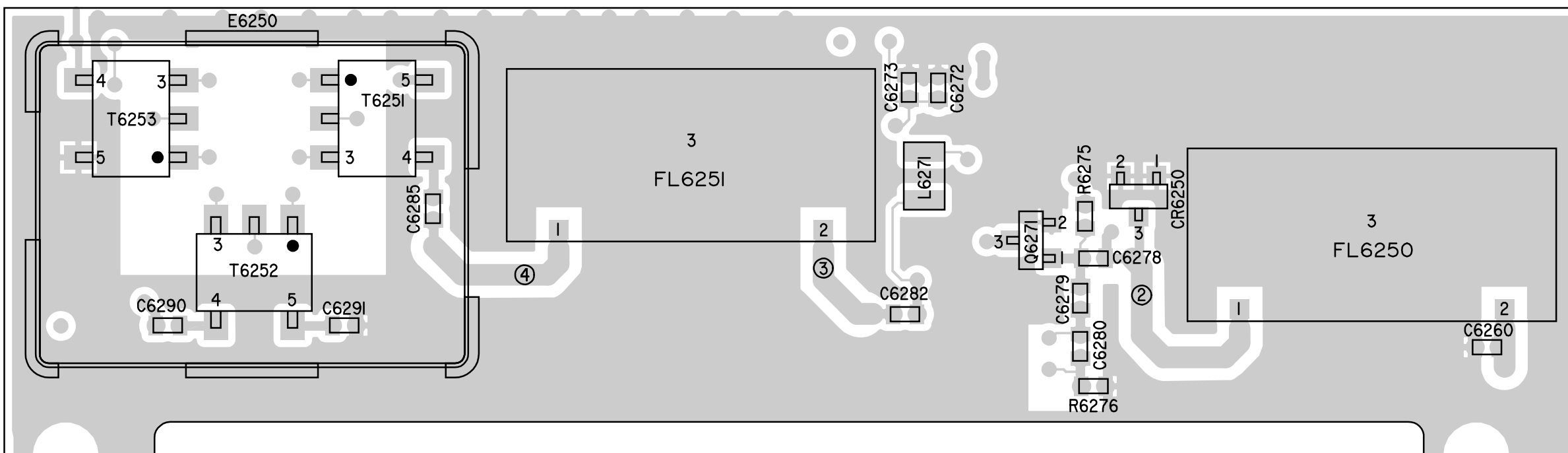

HEAVY COMPONENTS SIDE

MAEPF-25081-A

RECEIVER FRONT END PARTS LIST

REFERENCE SYMBOL	MOTOROLA PART NUMBER	DESCRIPTION
C6251	2113740F41	39pF
C6252	2113740F41	39pF
C6271	2113743K15	0.1uF
C6272	2113740F41	39pF
C6273	2113743K15	0.1uF
C6274	2113741F49	10nF
C6275	2113740F41	39pF
C6276	2113740F41	39pF
C6277	2113741F25	1nF
C6278	2113740F35	22pF
C6279	2113743K15	0.1uF
C6280	2113740F13	2.7pF
C6281	2113740F03	1.0pF
C6282	0662057A01	10-ohm Resistor
C6285	2113740F41	39pF
C6286	2113741F13	330pF
C6287	2311049A07	1uF
C6288	2113741F49	10nF
C6289	2113740F41	39pF
C6290	2113740F41	39pF
C6291	2113741F13	330pF
C6292	2113740F41	39pF
C6293	2113741F49	10nF
C6294	2311049A07	1uF
C6295	2113741F49	10nF
C6296	2113743E07	22nF
C6297	2113740F41	39pF
CR6250	4880154K03	Dual Schottky Mixer
FL6250	9102603S12	938-MHz Filter
FL6251	9102603S12	938-MHz Filter
L6271	2462587T17	150nH
L6272	2460591A11	7.6nH
L6273	2460591B04	11.03nH
L6274	2460591C23	13.8nH
Q6250	4805921T02	Special Rf Power Amplifier
Q6271	4882022N70	NPN
Q6272	4813824A17	PNP
R6250	0662057A73	10K
R6271	0662057A84	30K
R6272	0662057A69	6.8K
R6273	0662057A13	33
R6274	0662057A59	2.7K
R6275	0662057A59	2.7K
R6276	0662057A18	51

REFERENCE SYMBOL	MOTOROLA PART NUMBER	DESCRIPTION
R6285	0662057A29	150
R6286	0662057A65	4.7K
R6287	0662057A57	2.2K
R6291	0662057A13	33
R6292	0662057A41	470
R6293	0662057A01	10
R6294	0662057A41	470
T6251	2505515V03	4:1 BALUN
T6252	2505515V03	4:1 BALUN
T6253	2505515V07	Transformer, 25:1
U6251	5105625U28	Balanced GaAs Mixer
SH6201	2602660J01	TX Inj Shield
SH6202	2605261V01	2nd L.O. Shield
SH6250	2605915V01	TX Pwr Ampli Shield
Printed Circuit Boards (for reference only)		
	8404416P04 Issue P4	For Kits FLF5591A, B, C
	8404994E05 Issue P5	For Kits FLF5592A, B, C
	8408559Y01 Issue P1	For Kit FLF5604A
	8486005J01 Issue P1	For Kit FUF5752A
	8408497Y01 Issue P2	For Kit FLF5952A
	8408537Y01 Issue P2	For Kit FLF5606A
	8404416P05 Issue P5	For Kit HUF1190A
	8404994E05 Issue P5	For Kit HUF1191A

NOTES:

- All resistance values are in ohms unless indicated otherwise.
- Components shown on parts location and schematic diagrams but not included in parts list are not placed.

Receiver Front End (Kits FLF5591A, B, C; FLF5592A, B, C; FLF5604A; FUF5752A; FLF5952A; FLF5606A; HUF1190A; HUF1191A) Component Locations and Parts List

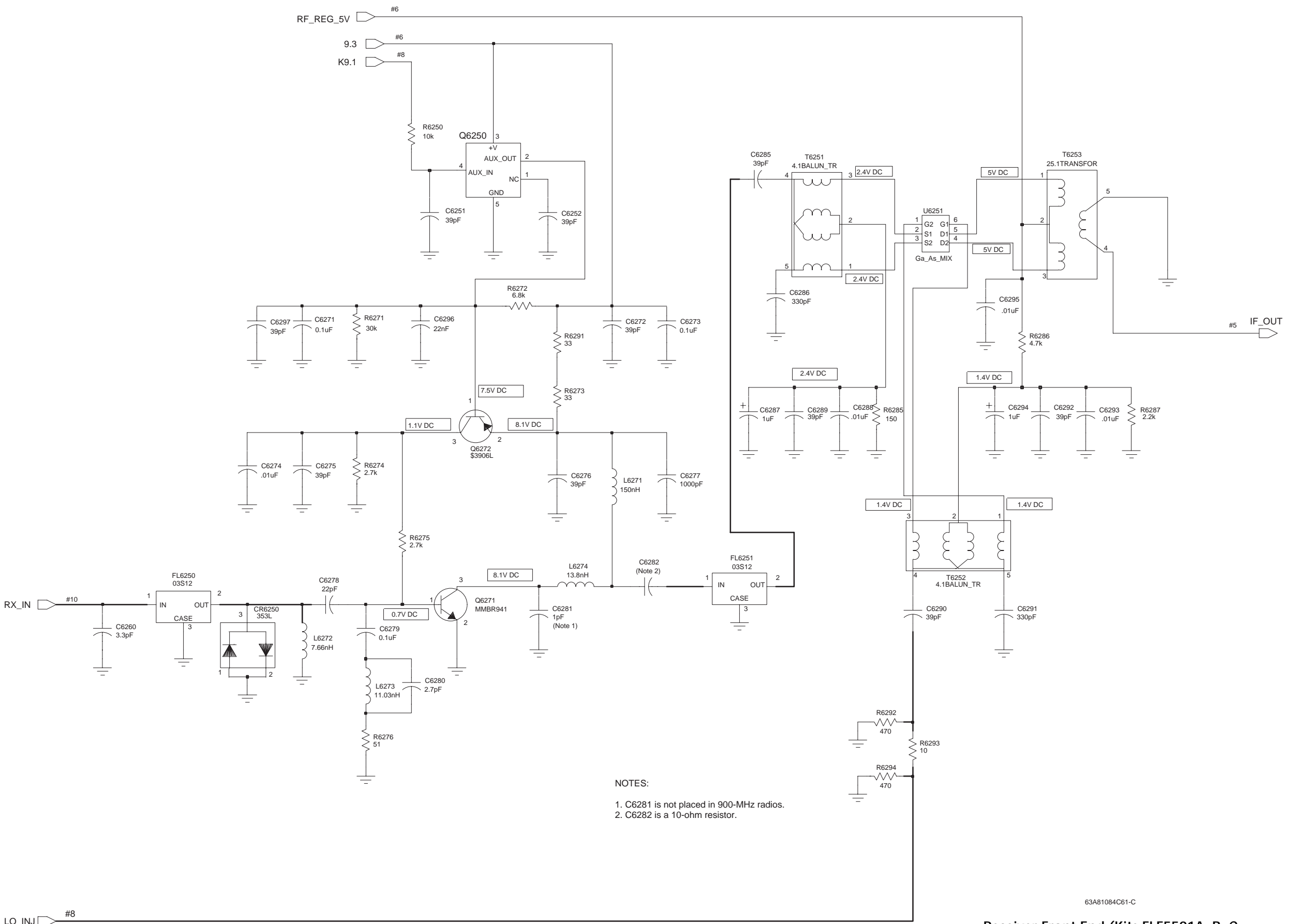

NOTES:
 1. C6281 is not placed in 900-MHz radios.
 2. C6282 is a 10-ohm resistor.

63A81084C61-C

Receiver Front End (Kits FLF5591A, B, C; FLF5592A, B, C; FLF5604A; FUF5752A; FLF5952A; FLF5606A; HUF1190A; HUF1191A) Schematic Diagram

RECEIVER IF COMPONENT LOCATIONS

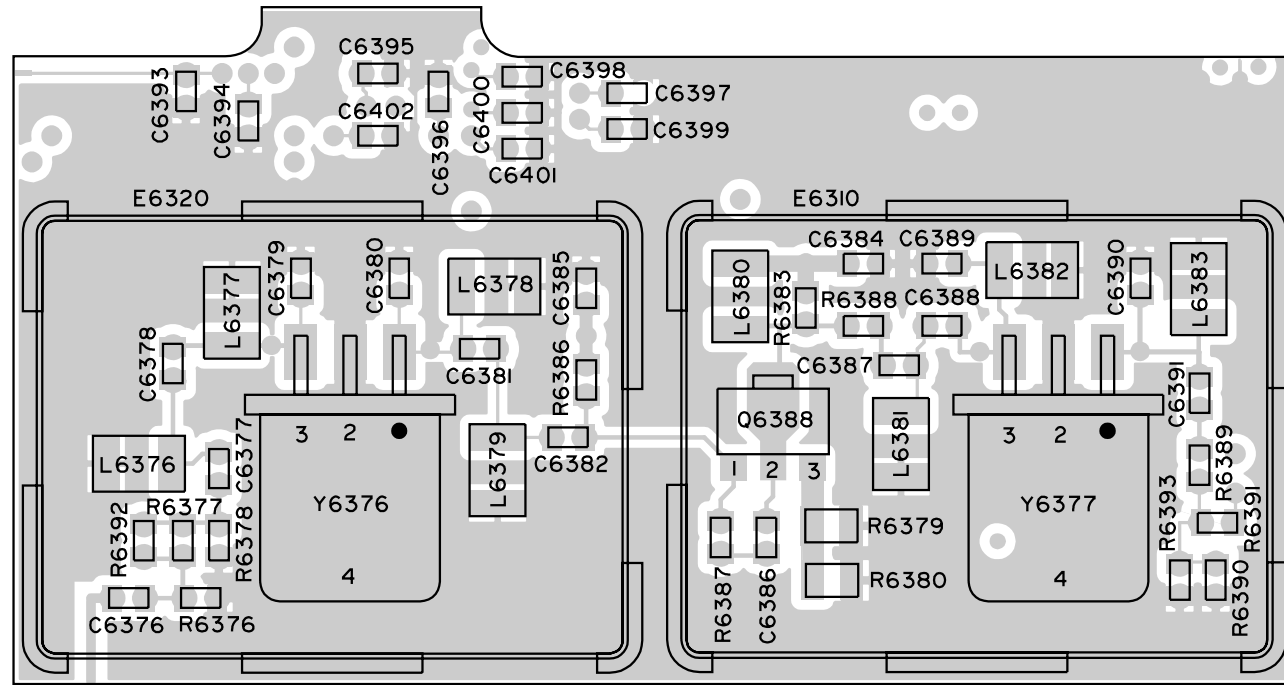

HEAVY COMPONENTS SIDE

MAEPF-25083-O

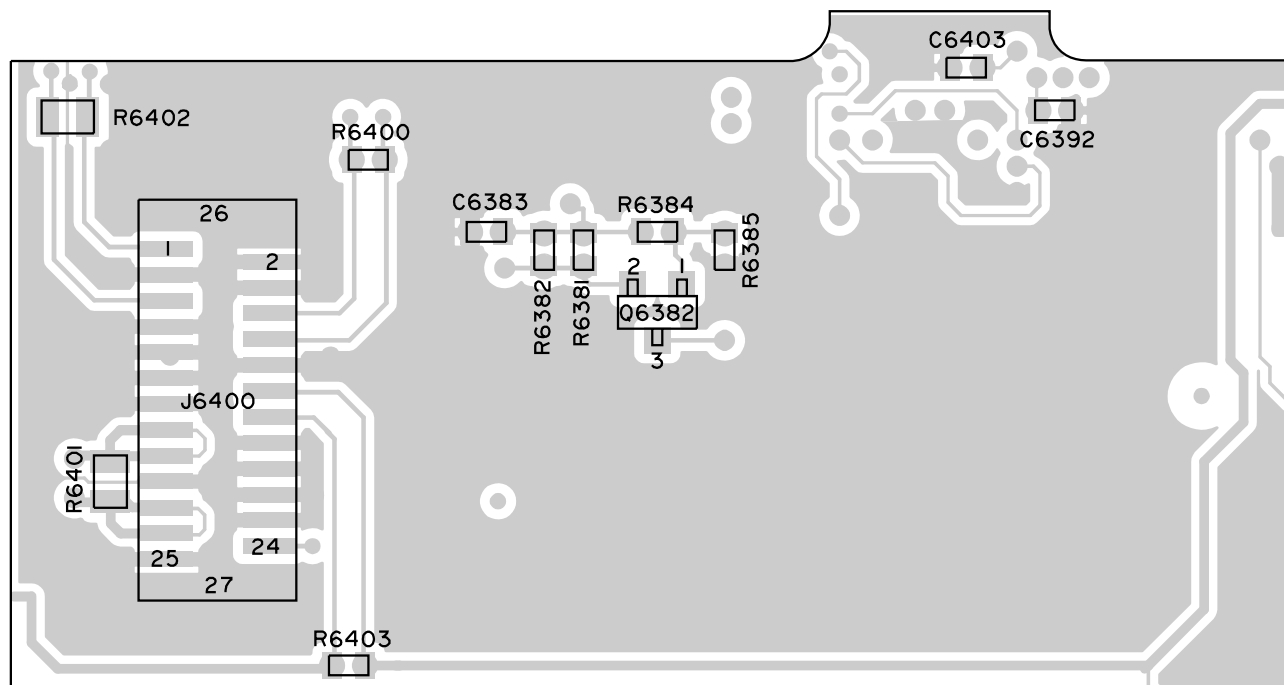

LIGHT COMPONENTS SIDE

MAEPF-25084-O

RECEIVER IF PARTS LIST

REFERENCE SYMBOL	MOTOROLA PART NUMBER	DESCRIPTION
		CAPACITORS:
C6376	2113741F49	0.01uF
C6377	2113740F37	27pF
C6378	2113740F22	6.2pF
C6381	2113740F22	6.2pF
C6382	2113740F31	15pF
C6383	2113741F49	0.01uF
C6384	2113741F49	0.01uF
C6385	2113741F49	0.01uF
C6386	2113741F49	0.01uF
C6387	2113740F31	15pF
C6388	2113740F22	6.2pF
C6391	0662057B47	0-ohm Resistor
C6392	2113740F41	39pF
C6393	2113740F41	39pF
C6394	2113740F41	39pF
C6395	2113740F41	39pF
C6396	2113740F41	39pF
C6397	2113740F41	39pF
C6398	2113740F41	39pF
C6399	2113740F41	39pF
C6400	2113740F41	39pF
C6401	2113740F41	39pF
C6402	2113740F41	39pF
C6403	2113740F41	39pF
C6404	0662057C01	0-ohm Resistor
J6400	0913915A18	Receptacle
J6401	2813916B13	Plug
		INDUCTORS:
L6376	2462587T22	390nH
L6377	2462587T30	1000nH
L6378	2462587T30	1000nH
L6379	2462587T22	390nH
L6380	2462587T30	1000nH
L6381	2462587T22	390nH
L6382	2462587T30	1000nH
L6383	2462587N66	820nH
		TRANSISTORS:
Q6382	4813824A17	PNP
Q6388	4882971R01	NPN
		RESISTORS:
R6376	0662057A49	1K
R6377	0662057A01	10
R6378	0662057A49	1K
R6380	0662057C19	4.7
R6381	0662057A35	270
R6382	0662057A37	330
R6383	0662057A25	100
R6384	0662057A56	2K
R6385	0662057A61	3.3K
R6386	0662057A56	2K

REFERENCE SYMBOL	MOTOROLA PART NUMBER	DESCRIPTION
R6387	0662057A41	470
R6388	0662057A18	51
R6389	0662057A29	150
R6391	0662057B47	0
R6392	0662057A01	10
R6400	0662057B47	0
R6401	0662057C01	0
R6402	0662057C01	0
R6403	0662057B47	0
		SHIELDS:
SH6310	2605915V01	Crystal Filter
SH6320	2605915V01	Crystal Filter
		FILTERS:
Y6376	4805846W02	Crystal BP 73.35/13; 80dB
Y6377	9102867C08	Crystal BP 73.35/13; 80dB
		PRINTED CIRCUIT BOARDS (For Reference Only):
	8404416P04 Issue P4	For Kits FLF5591A, B, C
	8404994E05 Issue P5	For Kits FLF5592A, B, C
	8404416P05 Issue P5	For Kits HUF1190A
	8404994E05 Issue P5	For Kits HUF1191A

NOTES:

- All resistance values are in ohms unless indicated otherwise.
- Components shown on parts location and schematic diagrams but not included in parts list are not placed.

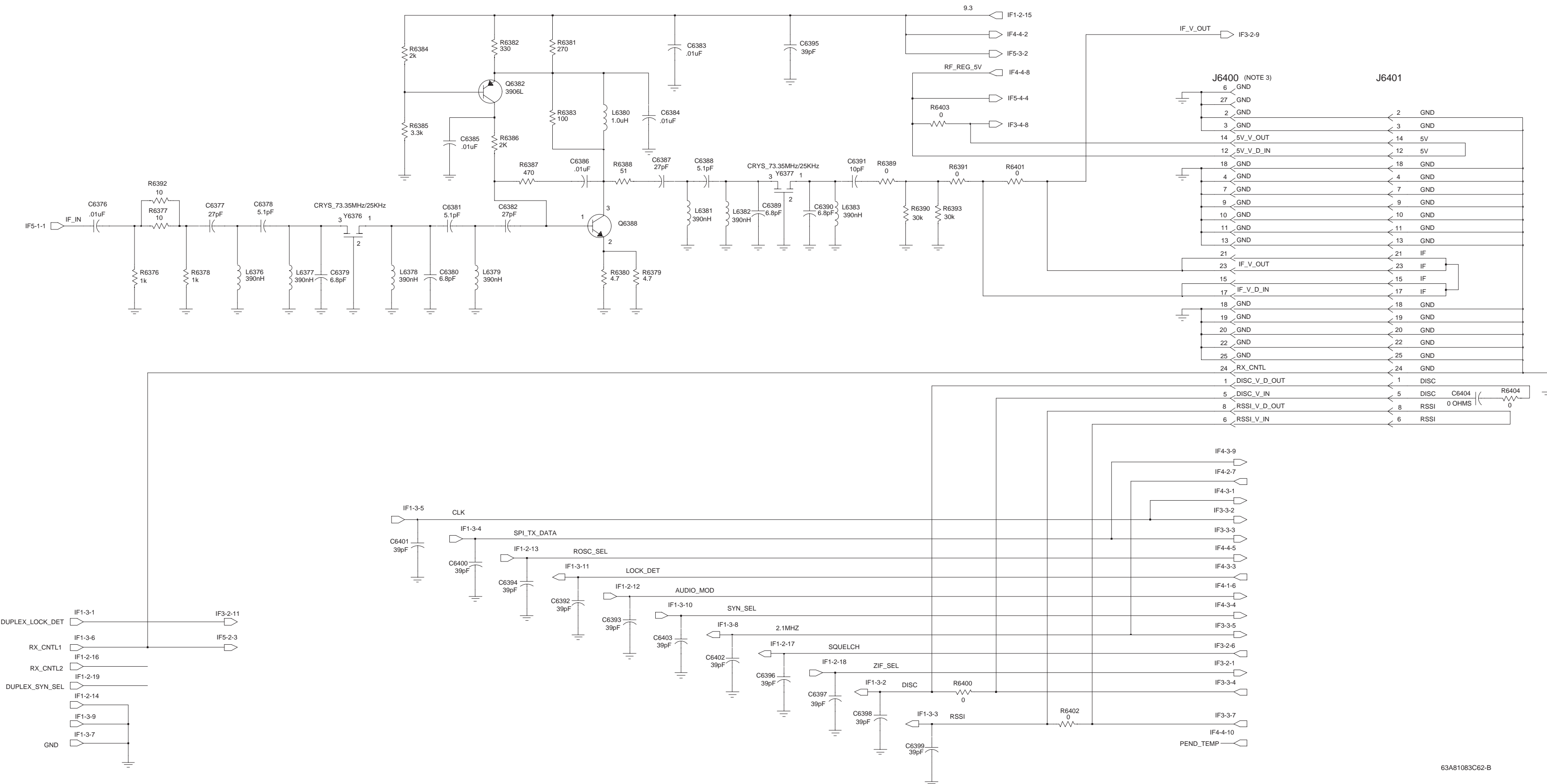

RECEIVER IF COMPONENT LOCATIONS

RECEIVER IF PARTS LIST

REFERENCE SYMBOL	MOTOROLA PART NUMBER	DESCRIPTION
L6380	2462587T30	1000nH
L6381	2462587T22	390nH
L6382	2462587T30	1000nH
L6383	2462587N66	820nH
Q6382	4813824A17	PNP
Q6388	4882971R01	NPN
R6342	0662057A73	10K
R6343	0662057A63	3.9K
R6344	0662057A73	10K
R6345	0662057A87	39K
R6346	0662057A89	47K
R6348	0662057A73	10K
R6349	0662057A73	10K
R6351	0662057A97	100K
R6352	0662057A17	47
R6353	0662057A17	47
R6354	0662057B14	470K
R6356	0662057A97	100K
R6357	0662057B47	0
R6358	0662057B02	150K
R6359	0611079E05	110K
R6360	0662057A86	36K
R6361	0662057A77	15K
R6362	0662057A97	100K
R6363	0662057A97	100K
R6364	0662057A17	47
R6365	0662057A17	47
R6366	0662057A17	47
R6367	0662057A17	47
R6368	0662057B14	470K
R6369	0662057B14	470K
R6370	0662057B14	470K
R6371	0662057B14	470K
R6372	0662057A97	100K
R6373	0662057A97	100K
R6374	0662057A89	47K
R6375	0662057B47	0
R6376	0662057A49	1K
R6377	0662057A01	10
R6378	0662057A49	1K
R6380	0662057C19	4.7
R6381	0662057A35	270
R6382	0662057A37	330
R6383	0662057A25	100
R6384	0662057A56	2K
R6385	0662057A61	3.3K
R6386	0662057A56	2K
R6387	0662057A41	470
R6388	0662057A18	51
R6389	0662057A29	150
R6391	0662057B47	0
R6392	0662057A01	10
SH6310	2605915V01	Crystal Filter
SH6320	2605915V01	Crystal Filter

REFERENCE SYMBOL	MOTOROLA PART NUMBER	DESCRIPTION
SH6330	2602660J02	AGC Circuit
SH6340	2602660J02	AGC Circuit
U6202	5113819A04	INTEGRATED CIRCUIT: Quad Operational Amplifier MC3303
Y6376	4805846W02	FILTERS: Crystal BP 73.35/13; 80dB
Y6377	4805846W04	FILTERS: Crystal BP 73.35/13; 70dB
	8408559Y01 Issue P1	For Kit FLF5604A
	8408537Y01 Issue P2	For Kit FLF5606A
	8408497Y01 Issue P2	For Kit FLF5952A
	8486005J01 Issue P1	For Kit FUF5752A

- NOTES:
- All resistance values are in ohms unless indicated otherwise.
 - Components shown on component location and schematic diagrams but not included in parts list are not placed.

REFERENCE SYMBOL	MOTOROLA PART NUMBER	DESCRIPTION
C6352	2113741F17	CAPACITORS: 470pF
C6353	2113741F17	470pF
C6354	2113743K16	0.22uF
C6355	2113741F17	470pF
C6356	2113743K16	0.22uF
C6357	2113743K15	0.1uF
C6358	2113741F17	470pF
C6359	2113741F17	470pF
C6360	2113741F17	470pF
C6361	2113741F17	470pF
C6362	2113741F45	6.8nF
C6363	2113741F17	470pF
C6364	2113743K15	0.1uF
C6365	2113743K15	0.1uF
C6367	2113741F17	470pF
C6368	2113741F17	470pF
C6369	2113741F17	470pF
C6370	2113741F17	470pF
C6371	2113741F17	470pF
C6372	2113741F17	470pF
C6373	2113741F17	470pF
C6374	2113741F17	470pF
C6376	2113741F49	0.01uF
C6377	2113740F31	15pF
C6378	2113740F22	6.2pF
C6381	2113740F22	6.2pF
C6382	2113740F31	15pF
C6383	2113741F49	0.01uF
C6384	2113741F49	0.01uF
C6385	2113741F49	0.01uF
C6386	2113741F49	0.01uF
C6387	2113740F31	15pF
C6388	2113740F22	6.2pF
C6391	0662057B47	0-ohm Resistor
C6392	2113740F41	39pF
C6393	2113740F41	39pF
C6394	2113740F41	39pF
C6395	2113740F41	39pF
C6396	2113740F41	39pF
C6397	2113740F41	39pF
C6398	2113740F41	39pF
C6399	2113740F41	39pF
C6400	2113740F41	39pF
C6401	2113740F41	39pF
C6402	2113740F41	39pF
C6403	2113740F41	39pF
CR6251	4805129M96	DIODES: PIN
CR6252	4805129M96	PIN
CR6253	4805129M96	PIN
CR6254	4805129M96	PIN
CR6255	4805129M96	PIN
CR6256	4805129M96	PIN
L6375	2462587T30	INDUCTORS: 1uH
L6376	2462587T22	390nH
L6377	2462587T30	1000nH
L6378	2462587T30	1000nH
L6379	2462587T22	390nH

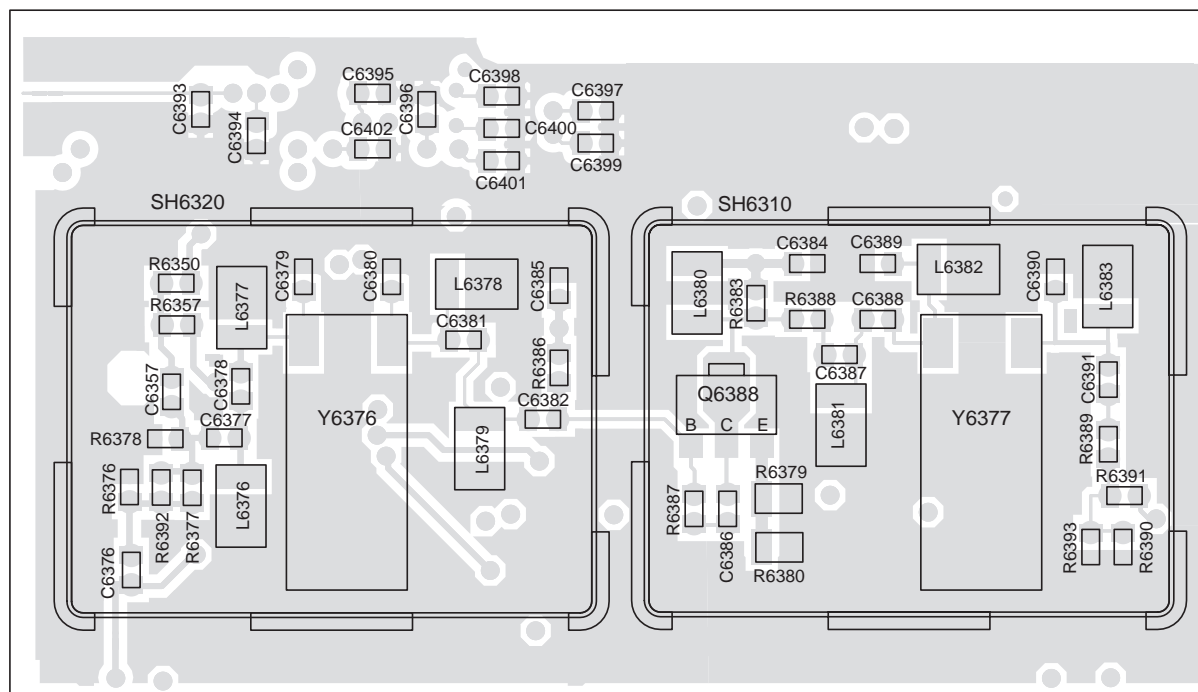

HEAVY COMPONENTS SIDE MAEPF-26321-O

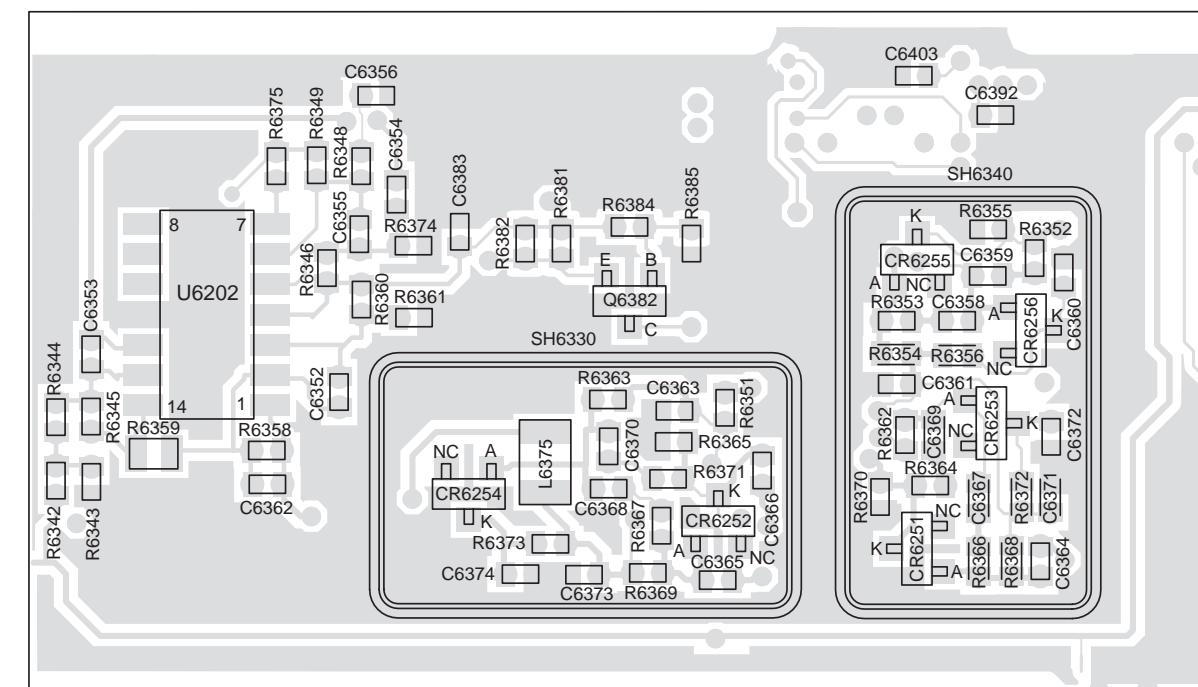

LIGHT COMPONENTS SIDE MAEPF-26322-O

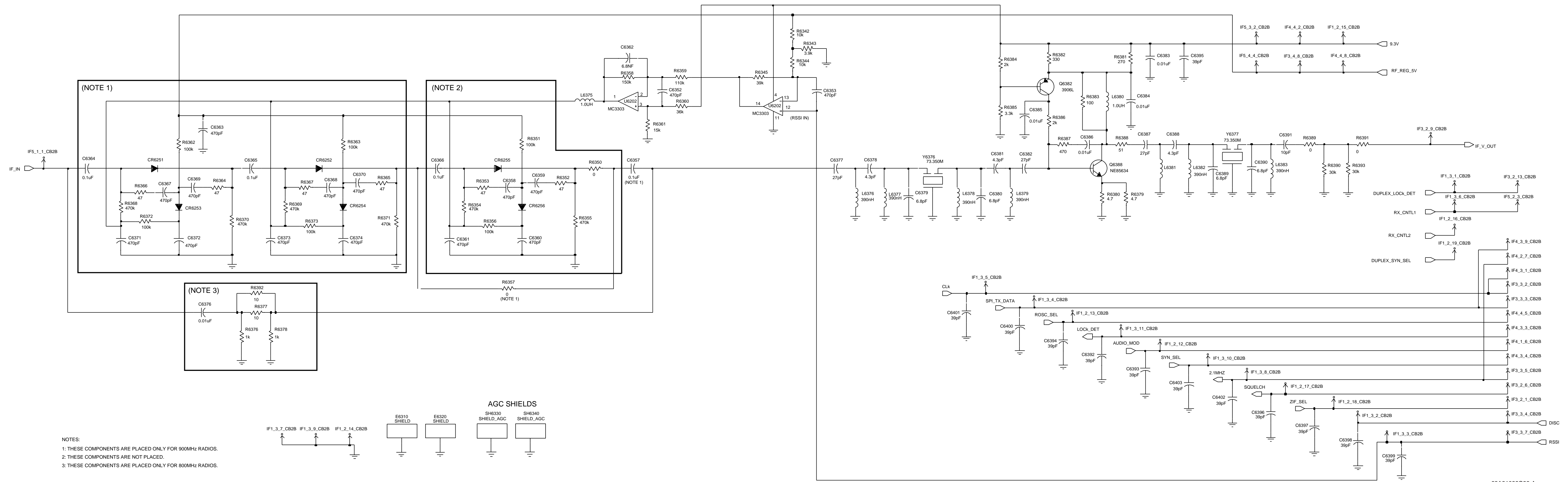

NOTES:
 1: THESE COMPONENTS ARE PLACED ONLY FOR 900MHz RADIOS.
 2: THESE COMPONENTS ARE NOT PLACED.
 3: THESE COMPONENTS ARE PLACED ONLY FOR 800MHz RADIOS.

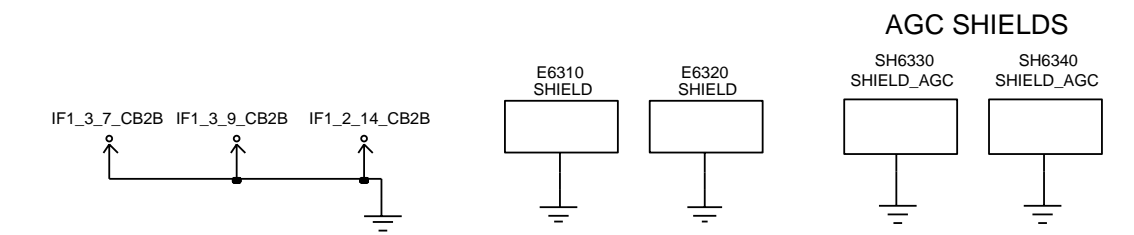

RECEIVER BACK END COMPONENT LOCATIONS

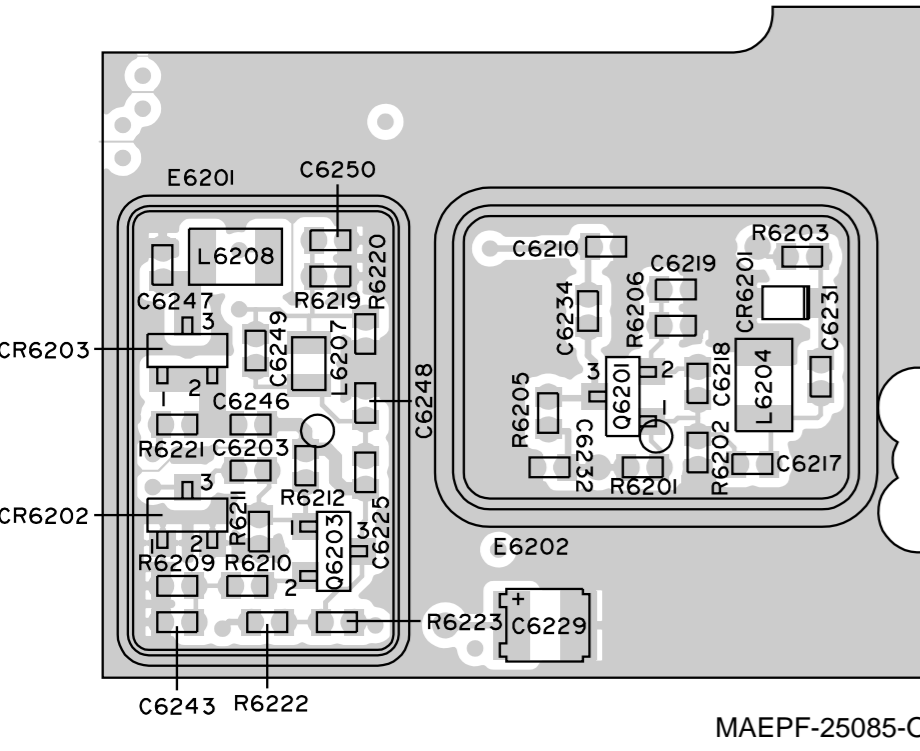

HEAVY
COMPONENTS
SIDE

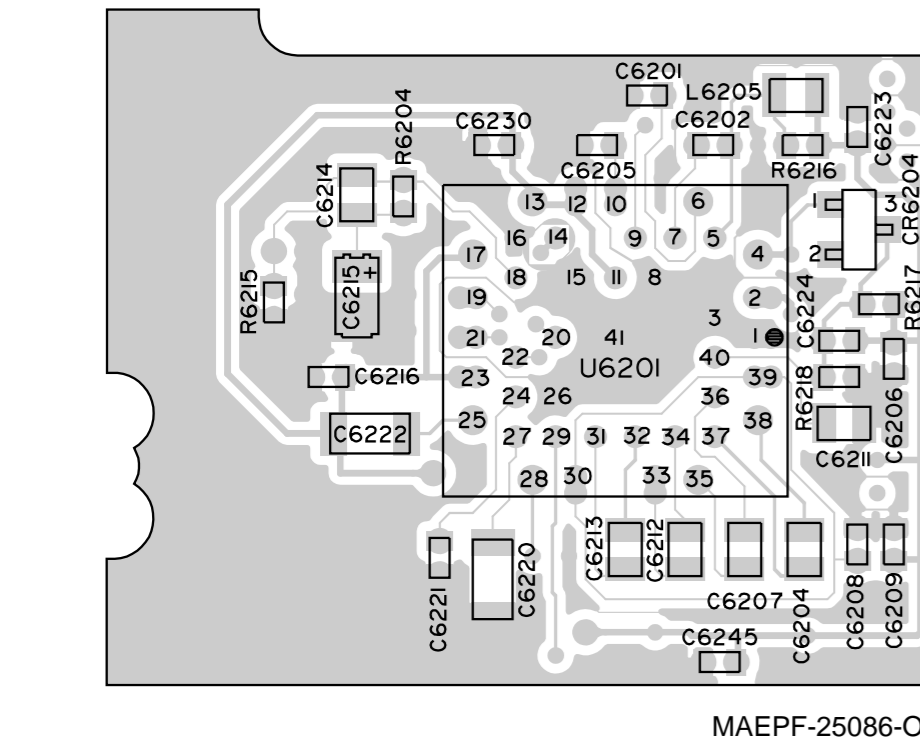

LIGHT
COMPONENTS
SIDE

RECEIVER BACK END PARTS LIST

REFERENCE SYMBOL	MOTOROLA PART NUMBER	DESCRIPTION
C6201	2113743K15	CAPACITORS: 0.1uF
C6202	2113740F51	100pF
C6203	2113743K15	0.1uF
C6204	2113743A23	0.22uF
C6205	2113741F25	1nF
C6206	2113743K15	0.1uF
C6207	2113743A23	0.22uF
C6208	2113743K15	0.1uF
C6209	2113743K15	0.1uF
C6210	2113740F25	8.2pF
C6211	2113743A19	0.1uF
C6212	2113743A23	0.22uF
C6213	2113743A23	0.22uF
C6214	2113741A51	18pF
C6215	2311049A02	0.15uF
C6216	2113743K15	0.1uF
C6217	2113740F41	39pF
C6218	2113740F42	43pF
C6219	2113740F42	43pF
C6220	2109720D14	0.1uF
C6221	2113741F17	470pF
C6222	2109720D14	0.1uF
C6223	2113743K15	0.1uF
C6224	2113743K15	0.1uF
C6225	2113743K15	0.1uF
C6229	2311049J23	10uF
C6230	2113743K15	0.1uF
C6231	2113740F41	39pF
C6232	2113743K15	0.1uF
C6234	2113740F11	2.2pF
C6243	2113743K15	0.1uF
C6245	2113743K15	0.1uF
C6246	2113743K15	0.1uF
C6247	2113743K15	0.1uF
C6249	2113740F03	1pF
C6404	0662057C01	0-ohm Resistor (On, jumper plug J6401)
CR6201	4862824C01	DIODES: Varactor
CR6203	4805129M96	Dual
CR6204	4880154K03	Dual Schottky Mixer
J6400	0913915A18	CONNECTORS: Receptacle
J6401	2813916B13	Jumper Plug
L6204	2462587T18	INDUCTORS: 180nH
L6205	2462587Q44	560nH
L6207	2462587Q40	270nH
L6208	2462587T30	1000nH

REFERENCE SYMBOL	MOTOROLA PART NUMBER	DESCRIPTION
Q6201	4882022N70	TRANSISTORS: NPN
Q6203	4882022N70	NPN
R6201	0662057A89	RESISTORS: 47K
R6202	0662057A89	47K
R6203	0662057A80	20K
R6204	0662057A59	2.7K
R6205	0662057A59	2.7K
R6206	0662057A59	2.7K
R6209	0662057A53	1.5K
R6210	0662057B47	0
R6211	0662057A84	30K
R6212	0662057A73	10K
R6215	0662057B05	200K
R6216	0662057A42	510
R6217	0662057A49	1K
R6219	0662057A65	4.7K
R6220	0662057A81	22K
R6221	0662057A44	620
R6222	0662057A73	10K
R6223	0662057A77	15K
R6404	0662057B47	0 (On, jumper plug J6401)
U6201	5105457W11	INTEGRATED CIRCUITS: Zero IF
	8404416P04 Issue P4	PRINTED CIRCUIT BOARDS (FOR REFERENCE ONLY): For Kits FLF5591A, B, C
	8404994E05 Issue P5	For Kits FLF5592A, B, C

- NOTES:
- All resistance values are in ohms unless indicated otherwise.
 - Components shown on component location and schematic diagrams but not included in parts list are not placed.

Receiver Back End (Kits FLF5591A, B, C;
FLF5592A, B, C) Component
Locations and Parts List

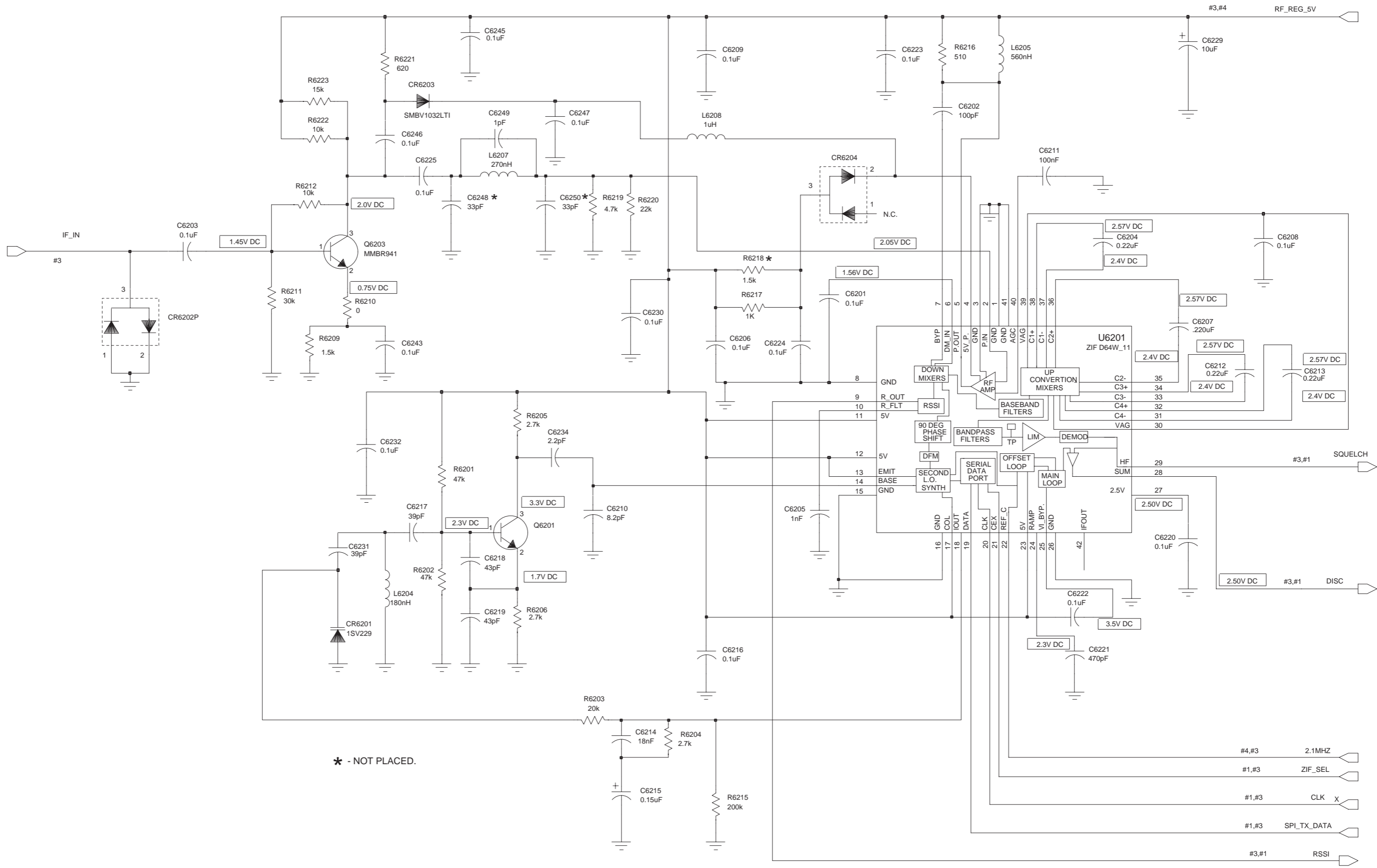

* - NOT PLACED.

RECEIVER BACK END COMPONENT LOCATIONS

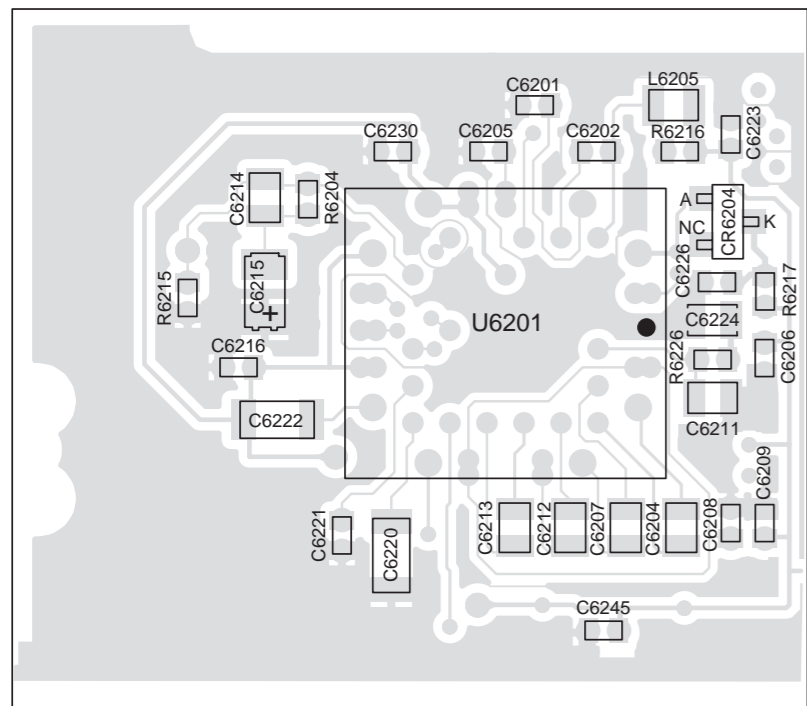

HEAVY
COMPONENTS
SIDE

MAEPF-26323-O

RECEIVER BACK END PARTS LIST

REFERENCE SYMBOL	MOTOROLA PART NUMBER	DESCRIPTION
C6201	2113743K15	0.1uF
C6202	2113740F51	100pF
C6203	2113743K15	0.1uF
C6204	2113743A23	0.22uF
C6205	2113740F59	220pF
C6206	2113743K15	0.1uF
C6207	2113743A23	0.22uF
C6208	2113743K15	0.1uF
C6209	2113743K15	0.1uF
C6210	2113740F25	8.2pF
C6211	2113743A19	0.1uF
C6212	2113743A23	0.22uF
C6213	2113743A23	0.22uF
C6214	2113741A51	18pF
C6215	2311049A02	0.15uF
C6216	2113743K15	0.1uF
C6217	2113740F41	39pF
C6218	2113740F42	43pF
C6219	2113740F42	43pF
C6220	2109720D14	0.1uF
C6221	2113741F17	470pF
C6222	2109720D14	0.1uF
C6223	2113743K15	0.1uF
C6224	2113743K15	0.1uF
C6225	2113743K15	0.1uF
C6229	2311049J23	10uF
C6230	2113743K15	0.1uF
C6231	2113740F41	39pF
C6232	2113743K15	0.1uF
C6234	2113740F11	2.2pF
C6243	2113743K15	0.1uF
C6245	2113743K15	0.1uF
C6247	2113743K15	0.1uF
C6249	2113740F03	1pF
CR6201	4862824C01	DIODES: Varactor
L6204	2462587T18	INDUCTORS: 180 nH
L6205	2462587Q44	560 nH
L6207	2462587Q40	270 nH
L6208	0611077A01	0-ohm resistor
Q6201	4882022N70	TRANSISTORS: NPN
Q6203	4882022N70	NPN
R6201	0662057A89	RESISTORS: 47K
R6202	0662057A89	47K
R6203	0662057A80	20K
R6204	0662057A59	2.7K
R6205	0662057A59	2.7K
R6206	0662057A59	2.7K
U6201	5105457W11	INTEGRATED CIRCUIT: Zero IF I.C.
	8408559Y01 Issue P1	PRINTED CIRCUIT BOARDS (For Reference Only): For Kit FLF5604A
	8408537Y01	For Kit FLF5606A
	Issue P2	
	8408497Y01	For Kit FLF5952A
	Issue P2	
	8486005J01 Issue P1	For Kit FUF5752A

REFERENCE SYMBOL	MOTOROLA PART NUMBER	DESCRIPTION
R6209	0662057A53	1.5K
R6210	0662057B47	0 Ohm
R6211	0662057A84	30K
R6212	0662057A73	10K
R6215	0662057B05	200K
R6216	0662057A42	510
R6217	0662057A49	1K
R6219	0662057A65	4.7K
R6220	0662057A81	22K
R6221	0662057A44	620
R6222	0662057A73	10K
R6223	0662057A77	15K
R6224	0662057B47	0

NOTES:

- All resistance values are in ohms unless indicated otherwise.
- Components shown on component location and schematic diagrams but not included in parts list are not placed.

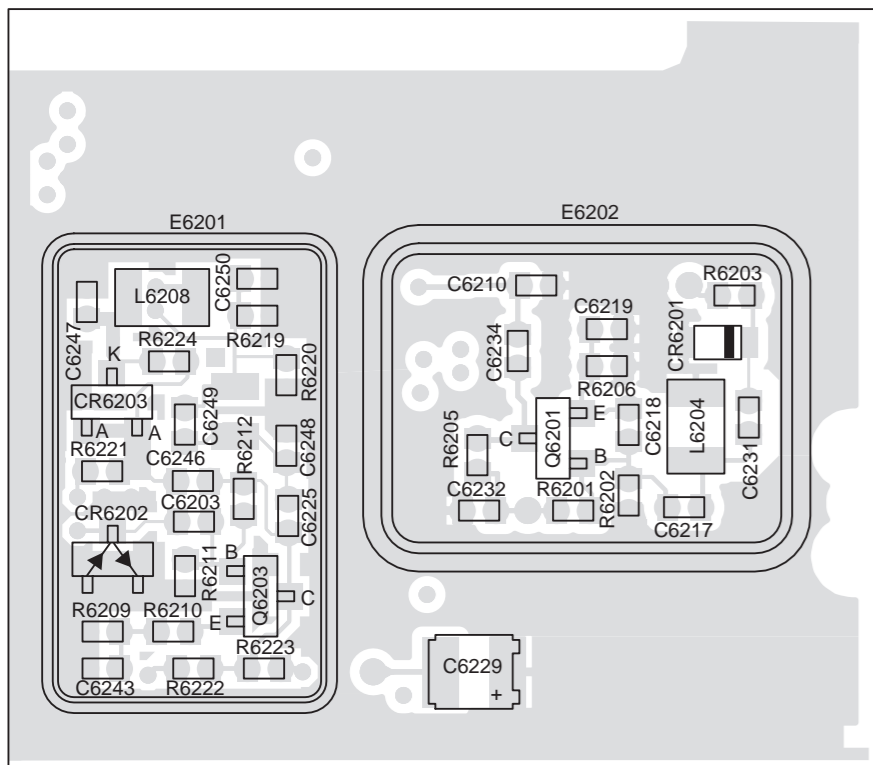

LIGHT
COMPONENTS
SIDE

MAEPF-26324-O

Receiver Back End (Kits FLF5604A,
FLF5606A, FLF5952A, FUF5752A)
Component Locations and Parts List

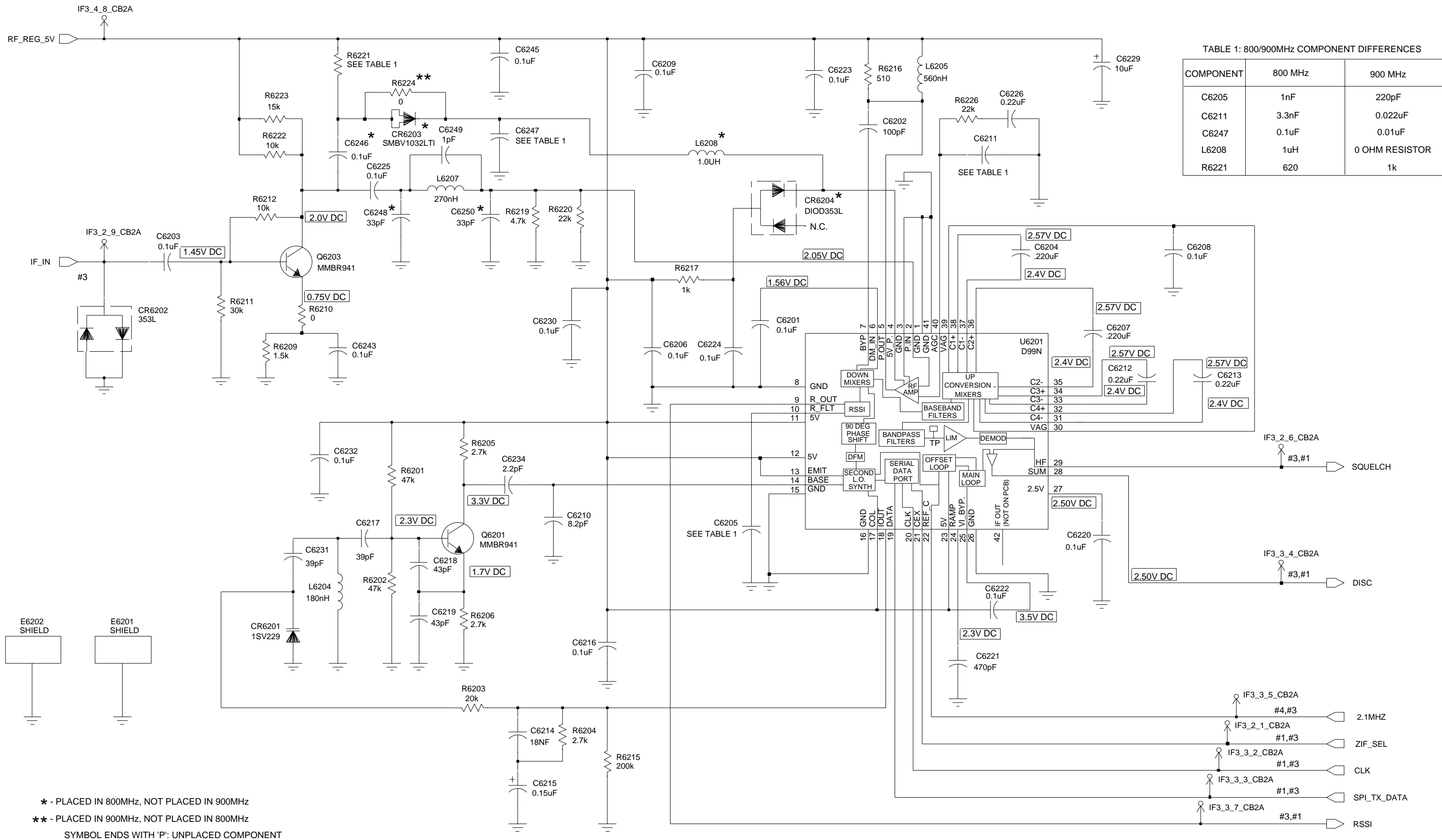

RECEIVER BACK END COMPONENT LOCATIONS

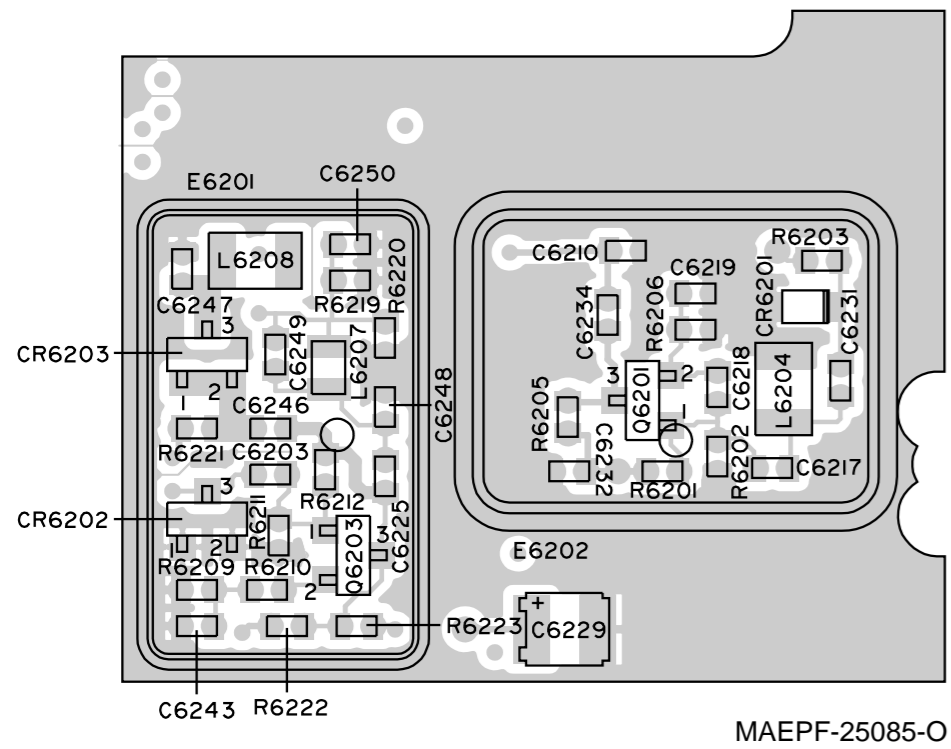

HEAVY COMPONENTS SIDE

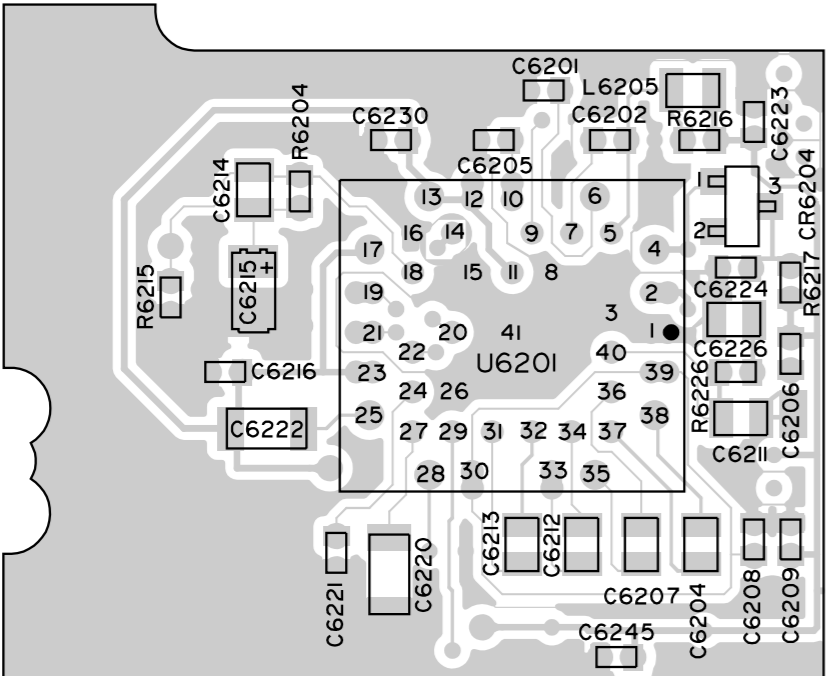

LIGHT COMPONENTS SIDE

RECEIVER BACK END PARTS LIST

REFERENCE SYMBOL	MOTOROLA PART NUMBER	DESCRIPTION
C6201	2113743K15	CAPACITORS: 0.1uF
C6202	2113740F51	100pF
C6203	2113743K15	0.1uF
C6204	2113743A23	0.22uF
C6205	2113741F25	1nF
C6206	2113743K15	0.1uF
C6207	2113743A23	0.22uF
C6208	2113743K15	0.1uF
C6209	2113743K15	0.1uF
C6210	2113740F25	8.2pF
C6211	2113741A33	3.3nF
C6212	2113743A23	0.22uF
C6213	2113743A23	0.22uF
C6214	2113741A51	18pF
C6215	2311049A02	0.15uF
C6216	2113743K15	0.1uF
C6217	2113740F41	39pF
C6218	2113740F42	43pF
C6219	2113740F42	43pF
C6220	2109720D14	0.1uF
C6221	2113741F17	470pF
C6222	2109720D14	0.1uF
C6223	2113743K15	0.1uF
C6224	2113743K15	0.1uF
C6225	2113743K15	0.1uF
C6226	2113743A23	0.22uF
C6229	2311049J23	10uF
C6230	2113743K15	0.1uF
C6231	2113740F41	39pF
C6232	2113743K15	0.1uF
C6234	2113740F11	2.2pF
C6243	2113743K15	0.1uF
C6245	2113743K15	0.1uF
C6246	2113743K15	0.1uF
C6247	2113743K15	0.1uF
C6249	2113740F03	1pF
C6404	0662057C01	0-ohm Resistor (On, jumper plug J6401)
CR6201	4862824C01	DIODES: Varactor
CR6203	4805129M96	Dual
CR6204	4880154K03	Dual Schottky Mixer
J6400	0913915A18	CONNECTORS: Receptacle
J6401	2813916B13	Jumper Plug
L6204	2462587T18	INDUCTORS: 180 nH
L6205	2462587Q44	560 nH
L6207	2462587Q40	270 nH
L6208	2462587T30	1000nH

REFERENCE SYMBOL	MOTOROLA PART NUMBER	DESCRIPTION
Q6201	4882022N70	TRANSISTORS: NPN
Q6203	4882022N70	NPN
R6201	0662057A89	RESISTORS: 47K
R6202	0662057A89	47K
R6203	0662057A80	20K
R6204	0662057A59	2.7K
R6205	0662057A59	2.7K
R6206	0662057A59	2.7K
R6209	0662057A53	1.5K
R6210	0662057B47	0
R6211	0662057A84	30K
R6212	0662057A73	10K
R6215	0662057B05	200K
R6216	0662057A42	510
R6217	0662057A49	1K
R6219	0662057A65	4.7K
R6220	0662057A81	22K
R6221	0662057A44	620
R6222	0662057A73	10K
R6223	0662057A77	15K
R6226	0662057A81	22K
U6201	5105835U69	INTEGRATED CIRCUITS: Zero IF I.C.
	8404416P05 Issue P5	PRINTED CIRCUIT BOARDS (For Reference Only): For kit HUF1190A
	8404994E05 Issue P5	For Kit HUF1191A

- NOTES:
- All resistance values are in ohms unless indicated otherwise.
 - Components shown on schematic diagram but not included in parts list are not placed.

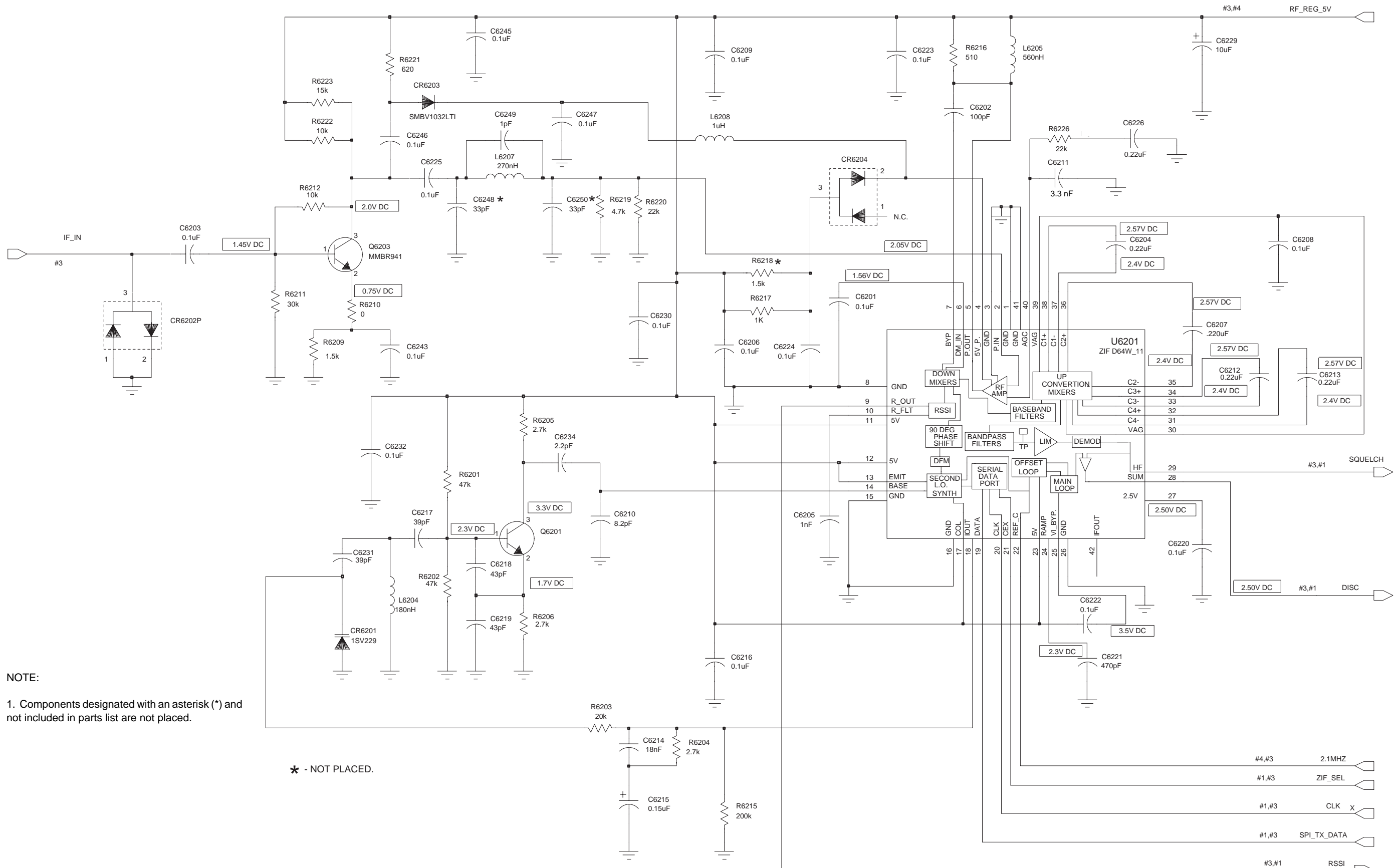

NOTE:

1. Components designated with an asterisk (*) and not included in parts list are not placed.

* - NOT PLACED.

12-WATT POWER AMPLIFIER COMPONENT LOCATIONS

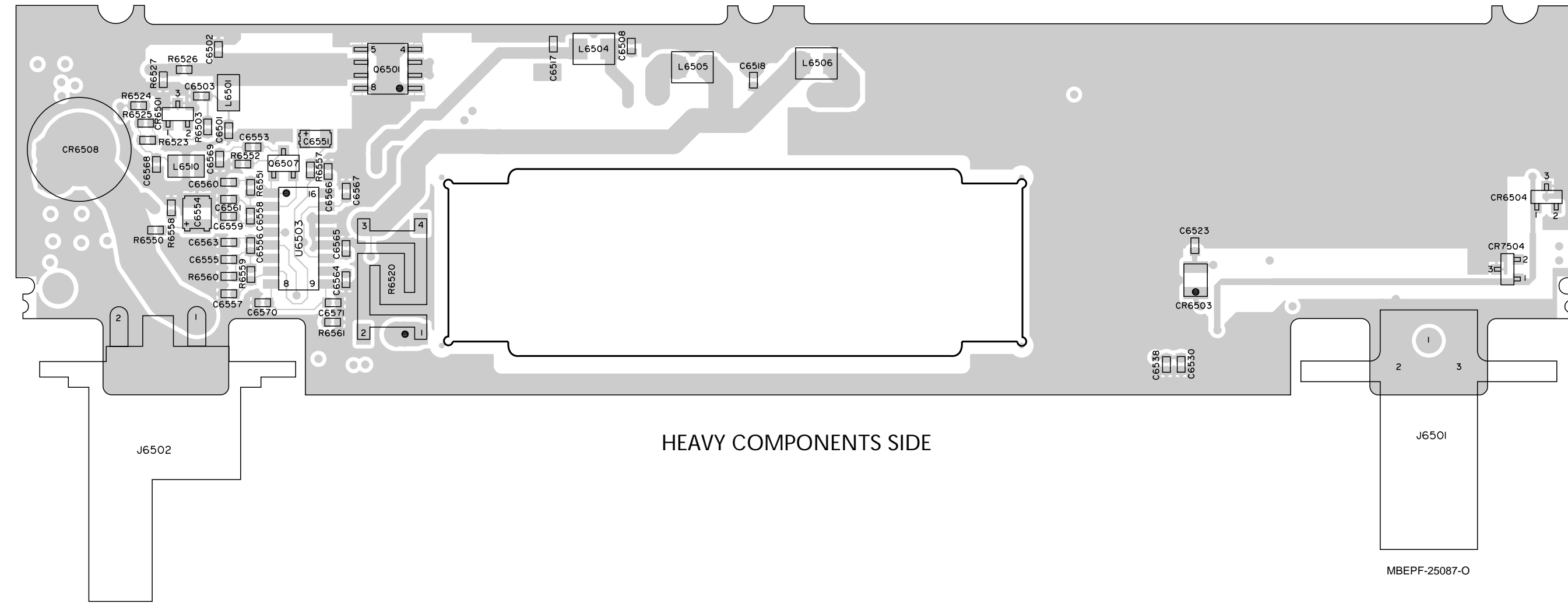

HEAVY COMPONENTS SIDE

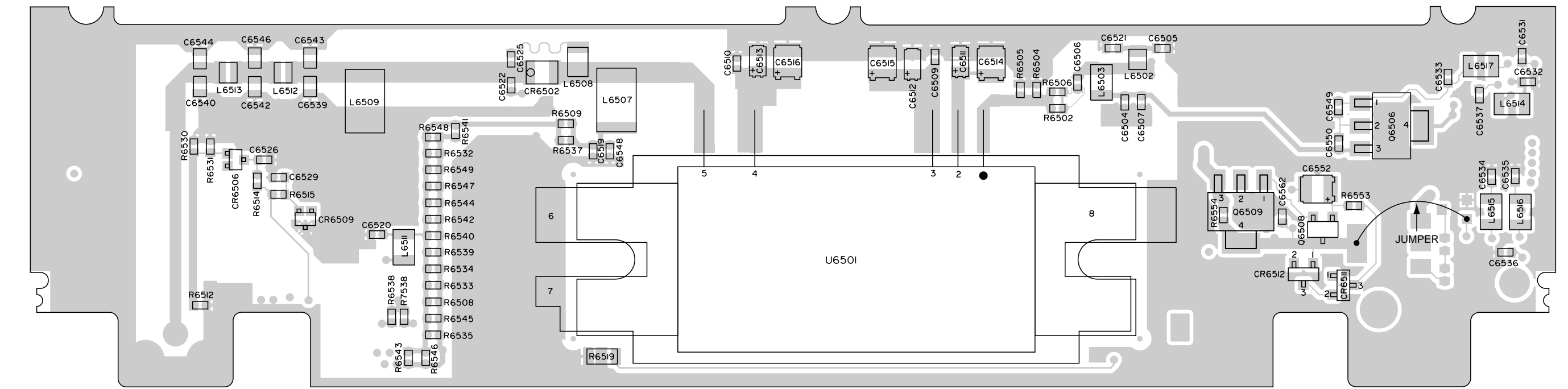

LIGHT COMPONENTS SIDE

12-WATT POWER AMPLIFIER PARTS LIST

REFERENCE SYMBOL	MOTOROLA PART NUMBER	DESCRIPTION
CAPACITORS:		
C6502	2113740F20	5.1pF
C6503	2113740F41	39pF
C6504	2113740F41	39pF
C6505	2113740F41	39pF
C6506	2113740F41	39pF
C6507	2113741F49	0.01uF
C6508	2113741F49	0.01uF
C6509	2113741F49	0.01uF
C6510	2113741F49	0.01uF
C6511	2311049A01	0.1uF
C6512	2311049A01	0.1uF
C6513	2311049A01	0.1uF
C6514	2311049A08	1uF
C6515	2311049A08	1uF
C6516	2311049A08	1uF
C6517	2113740F41	39pF
C6518	2113740F41	39pF
C6519	2113741F49	0.01uF
C6520	2113740F41	39pF

REFERENCE SYMBOL	MOTOROLA PART NUMBER	DESCRIPTION
C6521	2113741F49	0.01pF
C6522	2113740F41	39pF
C6523	2113740F20	5.1pF
C6525	2113741F20	5.1pF
C6526	2113740F27	10pF
C6529	2113740F41	39pF
C6531	2113740F41	39pF
C6532	2113740F41	39pF
C6533	2113740F41	39pF
C6534	2113740F41	39pF
C6535	2113740F41	39pF
C6536	2113740F41	39pF
C6537	2113740F41	39pF
C6538	2113740F41	39pF
C6539	211078A09	1.8pF
C6540	211078A09	1.8pF
C6542	2111078A17	3.3pF
C6543	2111078A09	1.8pF
C6544	2111078A09	1.8pF
C6546	2111078A17	3.3pF
C6548	2113740F41	39pF
C6549	2113741F49	0.01uF

REFERENCE SYMBOL	MOTOROLA PART NUMBER	DESCRIPTION
C6550	2113741F49	0.01uF
DIODES:		
CR6501	4813833C02	Dual 70V PIN
CR6502	4802482J02	PIN
CR6503	4802482J02	PIN
CR6506	4805218N57	Dual Schottky
CR6508	4880222R01	Zener
CR6509	4805218N57	Dual Schottky
CR7504	4805129M96	Dual Bonds
CONNECTORS:		
J6501	2804613P01	Antenna
J6502	0905902V01	Dc Power
INDUCTORS:		
L6501	2462587T13	68nH
L6502	2460591B04	11.03nH
L6503	2462587T13	68nH
L6504	2484657R01	Ferrite Bead
L6505	2484657R01	Ferrite Bead
L6506	2484657R01	Ferrite Bead
L6507	2460591R53	82nH
L6508	2460591E24	23.75nH
L6509	2460591R53	82nH
L6511	2462587T13	68nH
L6512	2460591A11	7.6nH
L6513	2460591A11	7.6nH

REFERENCE SYMBOL	MOTOROLA PART NUMBER	DESCRIPTION
L6514	2462587T13	68nH
L6515	2462587T13	68nH
L6516	2462587T13	68nH
L6517	2462587T13	68nH
TRANSISTORS:		
Q6501	4813827A26	NPN
Q6506	4813824B01	NPN
RESISTORS:		
R6502	0662057A09	22
R6503	0662057A01	10
R6504	0662057A41	470
R6505	0662057A49	1K
R6506	0662057A09	22
R6508	0662057A53	1.5K
R6509	0662057A15	39
R6512	0662057A25	100
R6514	0662057A61	3.3K
R6515	0662057A61	3.3K
R6519	0605621T02	Thermistor
R6520	1705603W01	Special Shunt
R6523	0662057A53	1.5K
R6524	0662057A53	1.5K
R6525	0662057A53	1.5K
R6526	0662057A01	10
R6527	0662057A37	330
R6530	0662057A25	100

REFERENCE SYMBOL	MOTOROLA PART NUMBER	DESCRIPTION
R6531	0662057A25	100
R6532	0662057A53	1.5K
R6533	0662057A53	1.5K
R6534	0662057A53	1.5K
R6535	0662057A53	1.5K
R6537	0662057A09	22
R6539	0662057A53	1.5K
R6540	0662057A53	1.5K
R6541	0662057A53	1.5K
R6542	0662057A53	1.5K
R6543	0662057A53	1.5K
R6544	0662057A53	1.5K
R6545	0662057A53	1.5K
R6546	0662057A53	1.5K
R6547	0662057A53	1.5K
R6548	0662057A53	1.5K
R6549	0662057A53	1.5K
R6554	0662057B47	0
R7538	0662057B47	0
INTEGRATED CIRCUITS:		
U6501	0198220029	Rf Power Amplifier Module

REFERENCE SYMBOL	MOTOROLA PART NUMBER	DESCRIPTION
		PRINTED CIRCUIT BOARDS (For Reference Only)
	8404416P04 Issue P4	For Kits FLF5591A, B, C
	8408559Y01 Issue P1	For Kit FLF5604A
	8404416P05 Issue P5	For Kit HUF1190A

- NOTES:
- All resistance values are in ohms unless indicated otherwise.
 - Components shown on component location and schematic diagrams but not included in parts list are not placed.

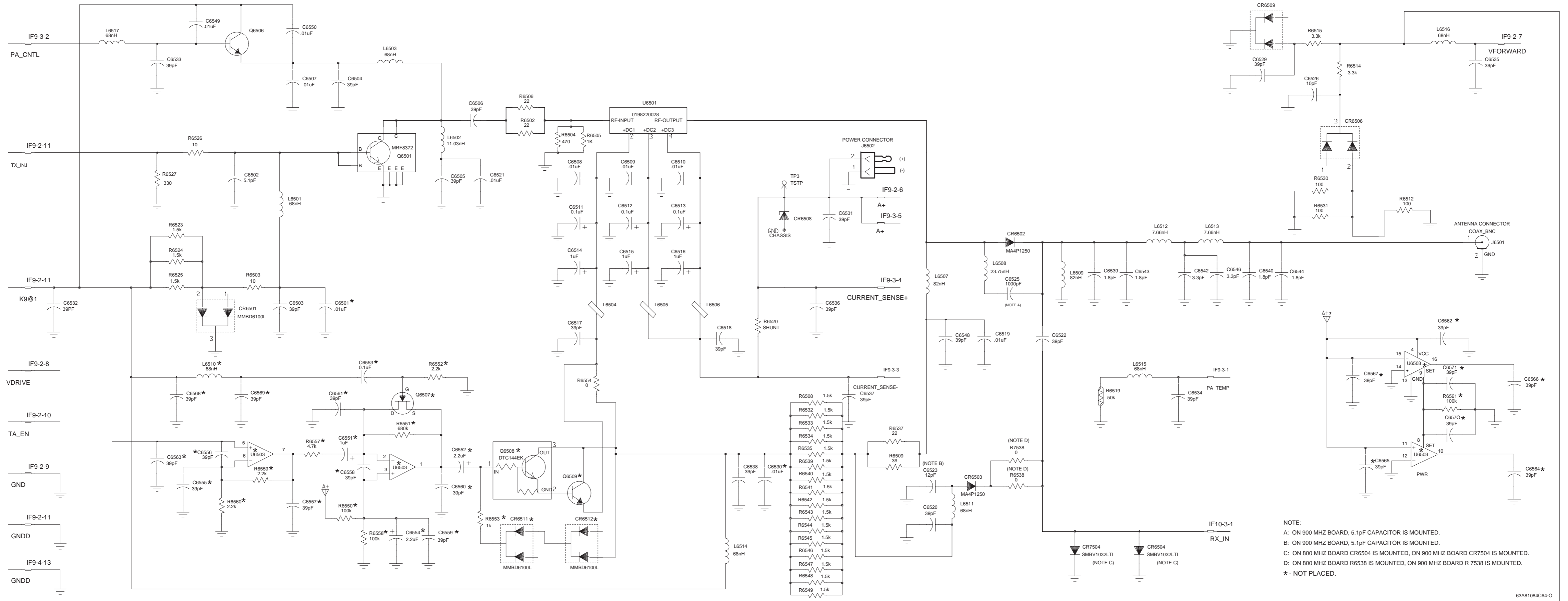

NOTE:
A: ON 900 MHZ BOARD, 5.1pF CAPACITOR IS MOUNTED.
B: ON 900 MHZ BOARD, 5.1pF CAPACITOR IS MOUNTED.
C: ON 800 MHZ BOARD CR6504 IS MOUNTED, ON 900 MHZ BOARD CR7504 IS MOUNTED.
D: ON 800 MHZ BOARD R6538 IS MOUNTED, ON 900 MHZ BOARD R 7538 IS MOUNTED.
* - NOT PLACED.

63A81084C64-O

12-Watt Power Amplifier (Kits FLF5591A, B, C; FLF5604A; HUF1190A) Schematic Diagram

12-WATT POWER AMPLIFIER COMPONENT LOCATIONS

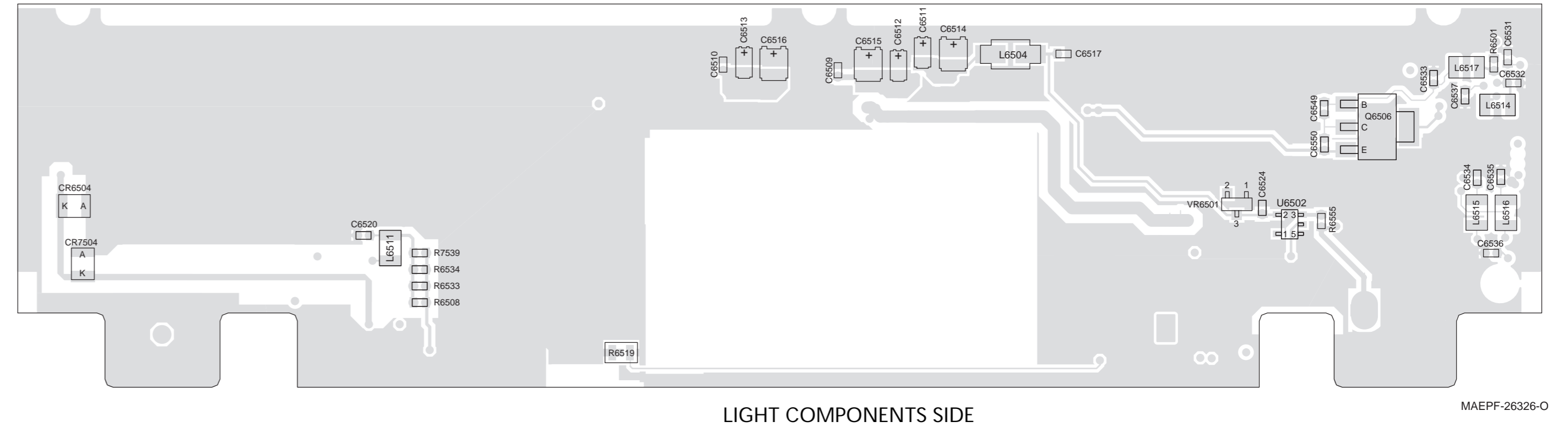
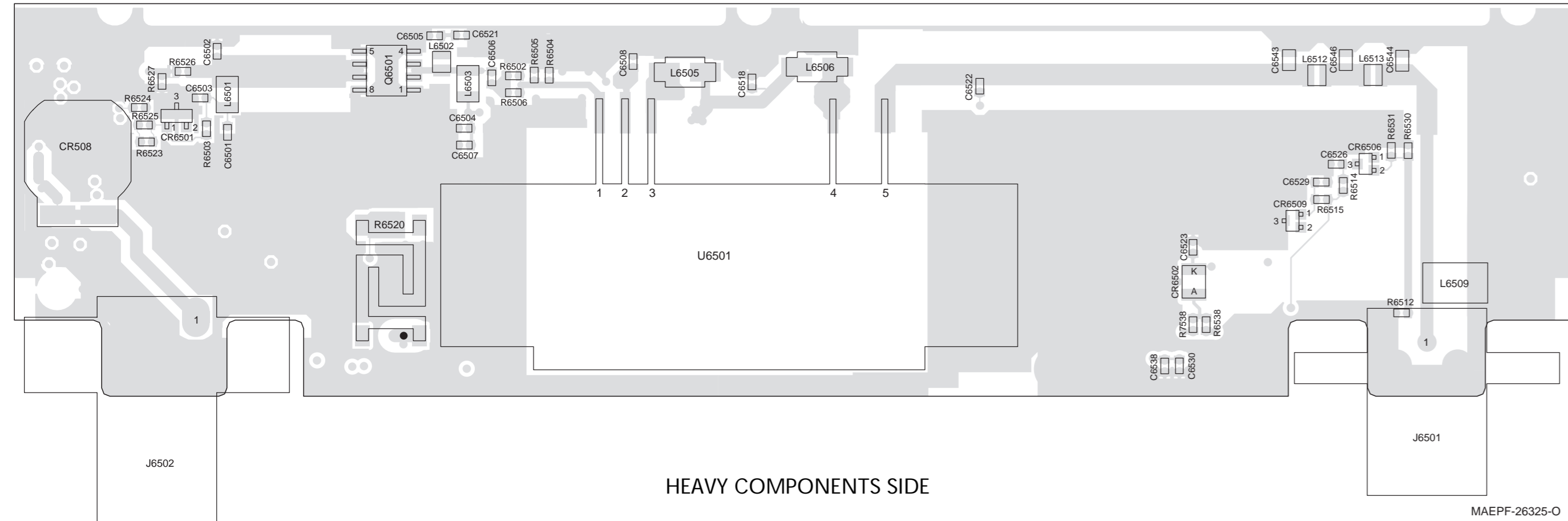

12-WATT POWER AMPLIFIER PARTS LIST

REFERENCE SYMBOL	MOTOROLA PART NUMBER	DESCRIPTION
CAPACITORS:		
C6501	2113741F49	0.01uF
C6502	2113740F15	3.3pF
C6503	2113740F41	39pF
C6504	2113740F41	39pF
C6505	2113740F41	39pF
C6506	2113740F41	39pF
C6507	2113741F49	0.01uF
C6508	2113741F49	0.01uF
C6509	2113741F49	0.01uF
C6510	2113741F49	0.01uF
C6511	2311049A01	0.1uF
C6512	2311049A01	0.1uF
C6513	2311049A01	0.1uF
C6514	2311049A08	1uF
C6515	2311049A08	1uF
C6516	2311049A08	1uF
C6517	2113740F41	39pF
C6518	2113740F41	39pF
C6520	2113740F41	39pF

REFERENCE SYMBOL	MOTOROLA PART NUMBER	DESCRIPTION
C6521	2113741F49	0.01pF
C6522	2113740F41	39pF
C6523	2113740F20	5.1pF
C6524	2113743E07	0.022uF
C6526	2113740F27	10pF
C6529	2113740F41	39pF
C6530	2113741F49	0.01uF
C6531	2113740F41	39pF
C6532	2113740F41	39pF
C6533	2113740F41	39pF
C6534	2113740F41	39pF
C6535	2113740F41	39pF
C6536	2113740F41	39pF
C6537	2113740F41	39pF
C6538	2113740F41	39pF
C6543	2113742H25	3pF
C6544	2113742H25	3pF
C6546	2113742H32	5.6pF
C6549	2113741F49	0.01uF
C6550	2113741F49	0.01uF

REFERENCE SYMBOL	MOTOROLA PART NUMBER	DESCRIPTION
CR6501	4813833C02	DIODES: Dual, 70V
CR6502	4802482J02	PIN
CR6506	4805218N57	Dual Schottky Over/Reverse Voltage Protection
CR6508	4813832C77	Dual Schottky Zener, 14V
CR6509	4805218N57	Dual Schottky Zener, 14V
VR6501	4813830A27	
J6501	0905901V06	CONNECTORS: Antenna
J6502	0905902V03	Dc Power
L6501	2462587T13	INDUCTORS: 68nH
L6502	2460591A11	7.6nH
L6503	2462587T13	68nH
L6504	2484657R01	Ferrite Bead
L6505	2484657R01	Ferrite Bead
L6506	2484657R01	Ferrite Bead
L6509	2460591R53	82nH
L6511	2462587T13	68nH
L6512	2460591A11	7.6nH
L6513	2460591A11	7.6nH
L6514	2462587T13	68nH
L6515	2462587T13	68nH

REFERENCE SYMBOL	MOTOROLA PART NUMBER	DESCRIPTION
L6516	2462587T13	68nH
L6517	2462587T13	68nH
Q6501	4813827A26	TRANSISTORS: NPN
Q6506	4813824B01	NPN
R6502	0662057A09	RESISTORS: 22
R6503	0662057A01	10
R6504	0662057A41	470
R6505	0662057A49	1K
R6506	0662057A09	22
R6508	0662057A53	1.5K
R6512	0662057A25	68nH
R6514	0662057A61	3.3K
R6515	0662057A61	3.3K
R6519	0680361L01	50K Thermistor
R6520	1705603W01	Special Shunt
R6523	0662057A53	1.5K
R6524	0662057A53	1.5K
R6525	0662057A53	1.5K
R6526	0662057A01	10
R6527	0662057A37	330
R6530	0662057A25	100
R6531	0662057A25	100

REFERENCE SYMBOL	MOTOROLA PART NUMBER	DESCRIPTION
R6533	0662057A53	1.5K
R6534	0662057A53	1.5K
R6555	0662057A33	220
R7538	0662057B47	0
R7539	0662057A53	1.5K
U6501	51MHW2820A	INTEGRATED CIRCUITS: RF Power Amplifier Module
U6502	4805921T02	Switch
	8408497Y01 Issue P2	PRINTED CIRCUIT BOARDS (For Reference Only): For Kit FLF5952A

- NOTE:
- All resistance values are in ohms unless indicated otherwise.
 - Components shown on component location and schematic diagrams but not included in parts list are not placed.

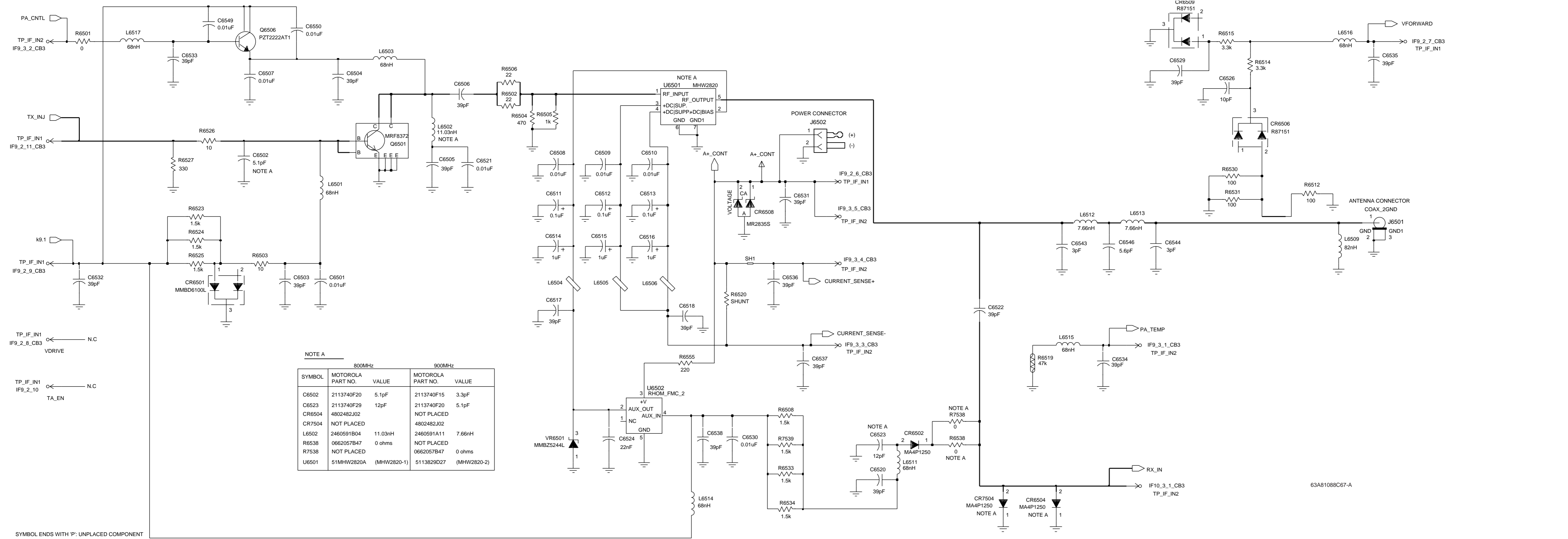

63A81088C67-A

30-WATT POWER AMPLIFIER COMPONENT LOCATIONS

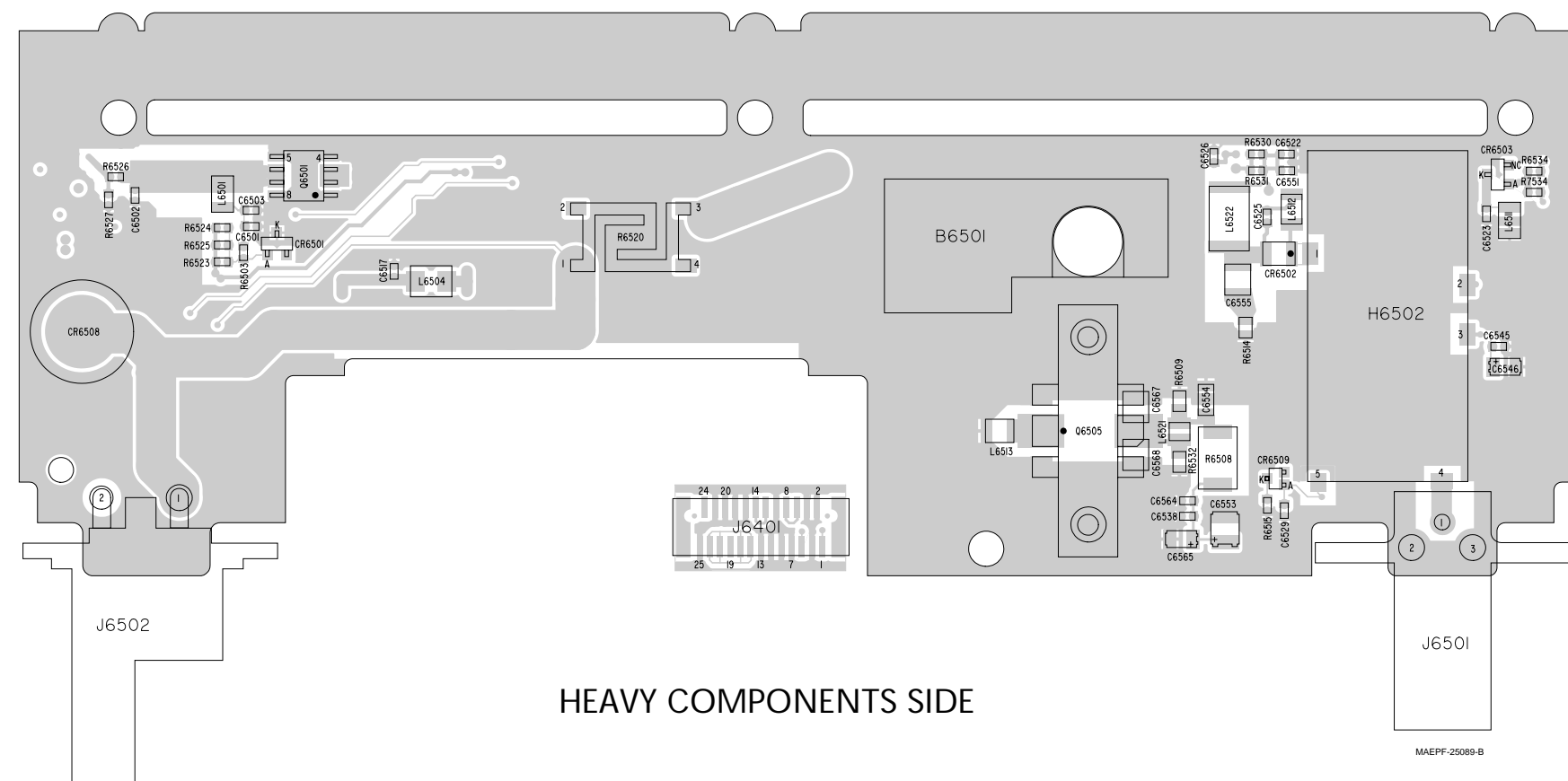

HEAVY COMPONENTS SIDE

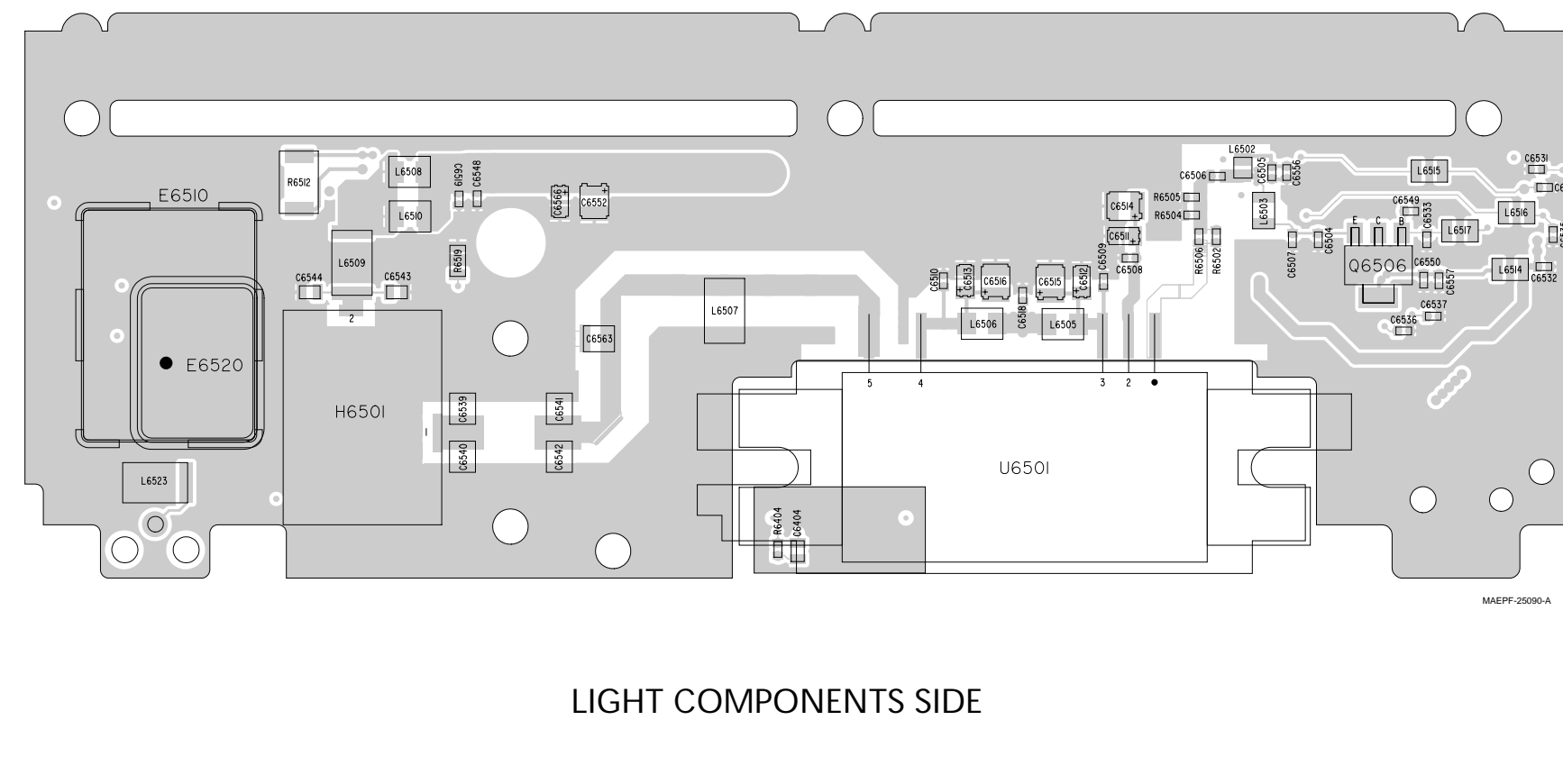

LIGHT COMPONENTS SIDE

30-WATT POWER AMPLIFIER PARTS LIST

REFERENCE SYMBOL	MOTOROLA PART NUMBER	DESCRIPTION
B6501	0704512P01	MISCELLANEOUS PARTS: Heat Sink
CAPACITORS:		
C6501	2113741F49	0.01uF
C6502	2113740F15	3.3pF
C6503	2113740F41	39pF
C6504	2113740F41	39pF
C6505	2113740F41	39pF
C6506	2113740F41	39pF
C6507	2113741F49	0.01uF
C6508	2113741F49	0.01uF
C6509	2113741F49	0.01uF
C6510	2113741F49	0.01uF
C6511	2311049A01	0.1uF
C6512	2311049A01	0.1uF
C6513	2311049A01	0.1uF
C6514	2311049A08	1uF
C6515	2311049A08	1uF
C6516	2311049A08	1uF
C6517	2113740F41	39pF
C6518	2113740F41	39pF
C6519	2113740F41	39pF
C6522	2113740F41	39pF
C6523	2113740F22	6.2pF
C6525	2113741F25	1000pF
C6526	2113740F41	39pF
C6529	2113740F41	39pF
C6531	2113740F41	39pF
C6532	2113740F41	39pF
C6533	2113740F41	39pF
C6534	2113740F41	39pF
C6535	2113740F41	39pF
C6536	2113740F41	39pF
C6537	2113740F41	39pF
C6538	2113741F49	0.01uF
C6539	2113742B22	10pF
C6540	2113742B22	10pF
C6541	2113742B22	10pF
C6542	2113742B22	10pF
C6545	2113741F49	0.01uF
C6546	2311049A01	0.1uF
C6548	2113741F49	0.01uF
C6549	2113741F25	1000pF
C6550	2113743K15	0.1uF
C6551	2113741F49	0.01uF

REFERENCE SYMBOL	MOTOROLA PART NUMBER	DESCRIPTION
C6552	2311049A08	1uF
C6553	2311049A08	1uF
C6554	2113740B39	39pF
C6555	2111078B45	130pF
C6556	2113741F49	0.01uF
C6557	2113740F41	39pF
C6563	2113742H24	2.7pF
C6564	2113741F25	1000pF
C6565	2311049A01	0.1uF
C6566	2311049A01	0.1uF
C6567	2113742B23	12pF
C6568	2113742B23	12pF
DIODES:		
CR6501	4813833C02	MMBD6100L
CR6502	4802482J02	MA4P1250
CR6503	4805129M96	SMBV1032LT1
CR6508	4880222R01	Zener, 28 Volts
CR6509	4805218N57	Schottky
SPECIAL MAGNETICS:		
H6501	0108704H03	Matching Hybrid
H6502	5102830B01	Harmonic Filter Hybrid
CONNECTORS:		
J6401	2813916B13	25-Pin Male SMD
J6501	0980322L01	Antenna
J6502	0905902V01	Dc Power
INDUCTORS:		
L6501	2462587T13	68nH
L6502	2460591A11	7.66nH
L6503	2462587T13	68nH
L6504	2484657R01	Ferrite Bead
L6505	2484657R01	Ferrite Bead
L6506	2484657R01	Ferrite Bead
L6508	2484657R01	Ferrite Bead
L6509	2460591R53	82nH
L6510	2484657R01	Ferrite Bead
L6511	2462587T13	68nH
L6512	2460591E24	23.75nH
L6513	2460591A01	5.2nH
L6514	2462587T13	68nH
L6515	2462587T13	68nH
L6516	2462587T13	68nH
L6517	2462587T13	68nH
L6521	2460591A11	7.6nH

REFERENCE SYMBOL	MOTOROLA PART NUMBER	DESCRIPTION
L6522	2460591R53	82nH
L6523	2460591R53	82nH
TRANSISTORS:		
Q6501	4813827A26	MRF8372 (NPN)
Q6505	4880225C20	MRF847/900MHz (NPN) (with coffin)
Q6506	4813824B01	PTZ2222AT1 (NPN)
RESISTORS:		
R6502	0662057A09	22
R6503	0662057A01	10
R6504	0662057A41	470
R6505	0662057A49	1K
R6506	0662057A09	22
R6508	0683962T17	4.7
R6509	0662057G13	100K
R6512	0683962T49	100K
R6514	0662057G13	100K
R6515	0662057A61	3.3K
R6519	0605621T02	50K Thermistor
R6520	1705603W01	Shunt
R6523	0662057A53	1.5K
R6524	0662057A53	1.5K
R6525	0662057A53	1.5K
R6526	0662057A01	10
R6527	0662057A37	330
R6530	0662057A15	39
R6531	0662057A09	22
R6532	0662057G13	100K
R7534	0662057B47	0.0
INTEGRATED CIRCUITS:		
U6501	0180522L01	Power Amplifier Module 900 MP MHW820-3
PRINTED CIRCUIT BOARDS (For Reference Only)		
	8404994E05 Issue P5	For Kit FLF5592A, B, C
	8486005J01 Issue P1	For Kit FUF5752A

NOTES:

- All resistance values are in ohms unless indicated otherwise.
- Components shown on parts location and schematic diagrams but not included in parts list are not placed.

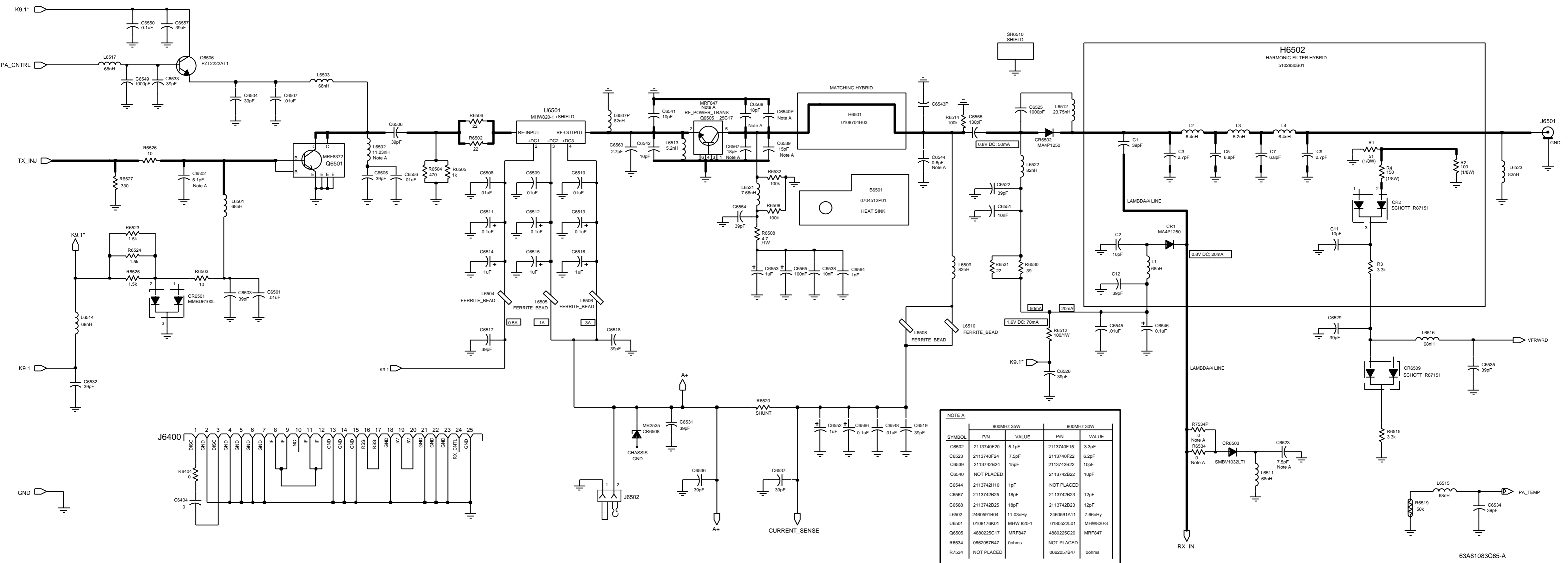

NOTE A

SYMBOL	800MHz 35W		900MHz 30W	
	P/N	VALUE	P/N	VALUE
C6502	2113740F20	5.1pF	2113740F15	3.3pF
C6523	2113740F24	7.5pF	2113740F22	6.2pF
C6539	2113742B24	15pF	2113742B22	10pF
C6540	NOT PLACED		2113742B22	10pF
C6544	2113742H10	1pF	NOT PLACED	
C6567	2113742B25	18pF	2113742B23	12pF
C6568	2113742B25	18pF	2113742B23	12pF
L6502	2460591B04	11.03nH	2460591A11	7.66nH
U6501	0108176K01	MHW 820-1	0180522L01	MHW820-3
Q6505	4880225C17	MRF847	4880225C20	MRF847
R6534	0662057B47	0ohms	NOT PLACED	
R7534	NOT PLACED		0662057B47	0ohms

SYMBOLS ENDING IN "P" ARE UNPLACED COMPONENTS.

63A81083C65-A

30-Watt Power Amplifier (Kits FLF5592A, B, C; FUF5752A; HUF1191A) Schematic Diagram

30-WATT POWER AMPLIFIER COMPONENT LOCATIONS

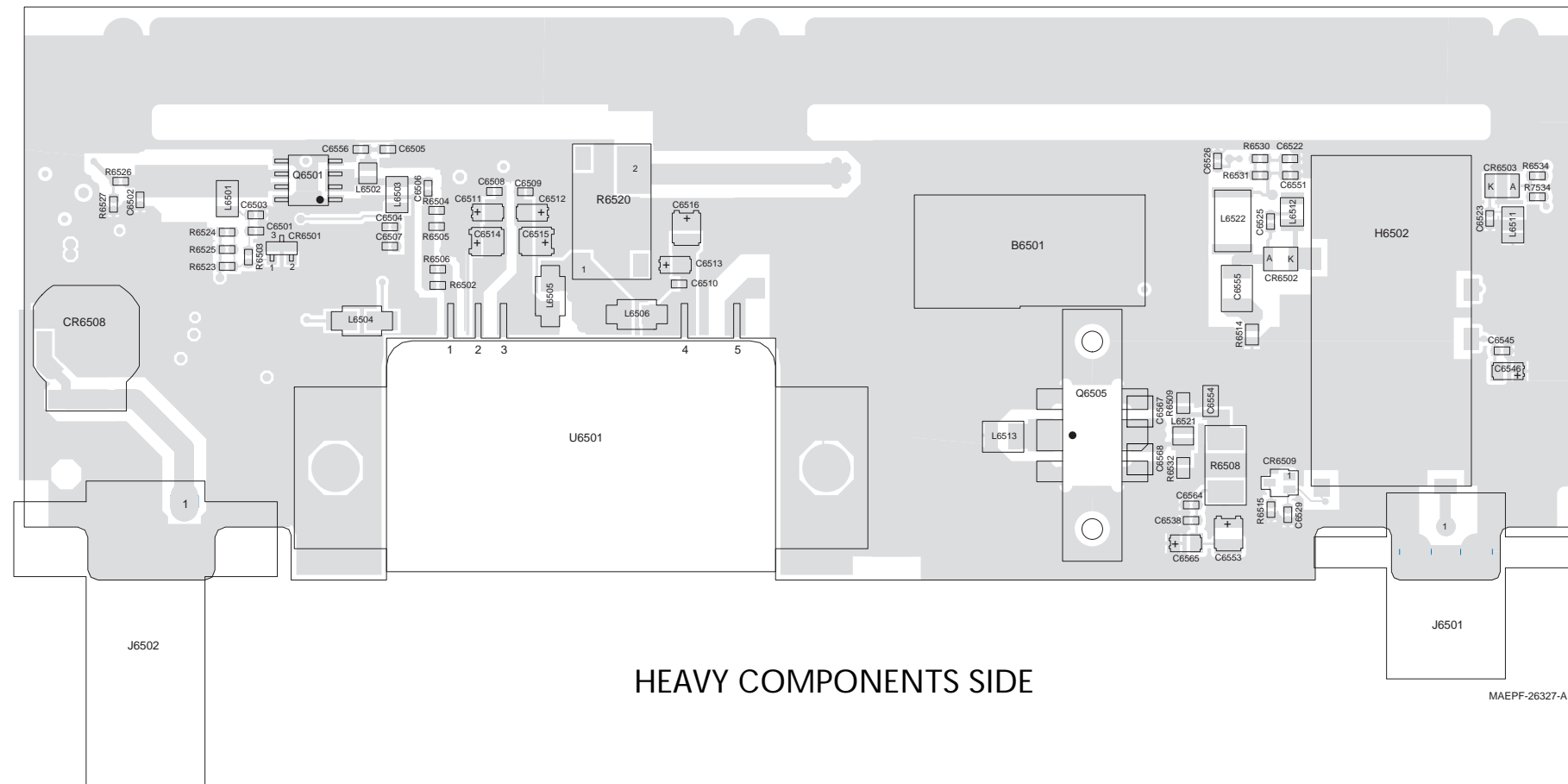

HEAVY COMPONENTS SIDE

MAEPF-26327-A

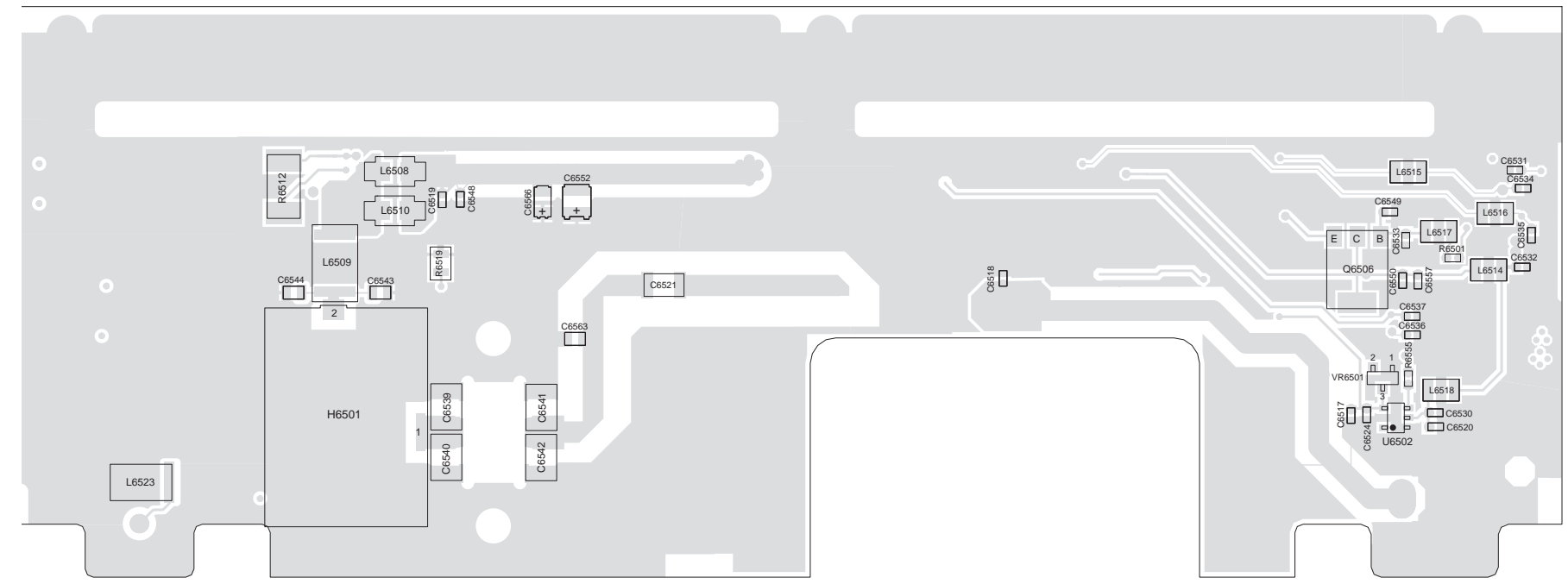

LIGHT COMPONENTS SIDE

MAEPF-26328-O

30-WATT POWER AMPLIFIER PARTS LIST

REFERENCE SYMBOL	MOTOROLA PART NUMBER	DESCRIPTION
B6501	0704512P01	MISCELLANEOUS PARTS: Heat Sink
C6501	2113741F49	0.01uF
C6502	2113740F15	3.3pF
C6503	2113740F41	39pF
C6504	2113740F41	39pF
C6505	2113740F41	39pF
C6506	2113740F41	39pF
C6507	2113741F49	0.01uF
C6508	2113741F49	0.01uF
C6509	2113741F49	0.01uF
C6510	2113741F49	0.01uF
C6511	2311049A01	0.1uF
C6512	2311049A01	0.1uF
C6513	2311049A01	0.1uF
C6514	2311049A08	1uF
C6515	2311049A08	1uF
C6516	2311049A08	1uF
C6517	2113740F41	39pF
C6518	2113740F41	39pF
C6519	2113740F41	39pF
C6520	2113740F41	39pF
C6522	2113740F41	39pF
C6523	2113740F27	10pF
C6524	2113743E07	0.022uF
C6525	2113741F25	1000pF
C6526	2113740F41	39pF
C6529	2113740F41	39pF
C6530	2113741F49	0.01uF
C6531	2113740F41	39pF
C6532	2113740F41	39pF
C6533	2113740F41	39pF
C6534	2113740F41	39pF
C6535	2113740F41	39pF
C6536	2113740F41	39pF
C6537	2113740F41	39pF
C6538	2113741F49	0.01uF
C6539	2113742B22	10pF
C6540	2113742B22	10pF
C6541	2113742B22	10pF
C6542	2113742B22	10pF
C6545	2113741F49	0.01uF
C6546	2311049A01	0.1uF
C6548	2113741F49	0.01uF
C6549	2113741F25	1000pF

REFERENCE SYMBOL	MOTOROLA PART NUMBER	DESCRIPTION
C6550	2113741F49	0.01uF
C6551	2113741F49	0.01uF
C6552	2311049A08	1uF
C6553	2311049A08	1uF
C6554	2113740B39	39pF
C6555	2111078B45	130pF
C6556	2113741F49	0.01uF
C6557	2113740F41	39pF
C6563	2113742H24	2.7pF
C6564	2113741F25	1000pF
C6565	2311049A01	0.1uF
C6566	2311049A01	0.1uF
C6567	2113742B23	12pF
C6568	2113742B23	12pF
CR6501	4813833C02	DIODES: Dual 70V
CR6502	4802482J02	PIV
CR6503	4802482J02	PIV
CR6508	4813832C77	Ov/Rvs Voltage Protect
CR6509	4805218N57	Dual Schottky
VR6501	4813830A27	Zener, 14 Volts
H6501	0108704H03	SPECIAL MAGNETICS: Matching Hybrid
H6502	5102830B01	Harmonic Filter Hybrid
J6501	0905901V06	CONNECTORS: Antenna
J6502	0905902V03	Dc Power
L6501	2462587T13	INDUCTORS: 68nH
L6502	2460591A11	7.6nH
L6503	2462587T13	68nH
L6504	2484657R01	Ferrite Bead
L6505	2484657R01	Ferrite Bead
L6506	2484657R01	Ferrite Bead
L6508	2484657R01	Ferrite Bead
L6509	2460591R53	82nH
L6510	2484657R01	Ferrite Bead
L6511	2462587T13	68nH
L6512	2460591E24	23.75nH
L6513	2460591A01	5.2nH
L6514	2462587T13	68nH
L6515	2462587T13	68nH
L6516	2462587T13	68nH

REFERENCE SYMBOL	MOTOROLA PART NUMBER	DESCRIPTION
L6517	2462587T13	68nH
L6518	2460597T13	68nH
L6521	2460591A11	7.6nH
L6522	2460591R53	82nH
L6523	2460591R53	82nH
Q6501	4813827A26	TRANSISTORS: MRF8372 (NPN)
Q6505	4880225C20	M25C20 (NPN)
Q6506	4813824B01	PZT222AT1 (NPN)
R6502	0662057A09	RESISTORS: 22
R6503	0662057A01	10
R6504	0662057A41	470
R6505	0662057A49	1K
R6506	0662057A09	22
R6508	0683962T17	4.7
R6509	0662057G13	100K
R6512	0683962T49	100
R6514	0662057G13	100K
R6515	0662057A61	3.3K
R6519	0680361L01	50K Thermistor
R6520	1705603W01	Special Shunt
R6523	0662057A53	1.5K
R6524	0662057A53	1.5K
R6525	0662057A53	1.5K
R6526	0662057A01	10
R6527	0662057A37	330
R6530	0662057A15	39
R6531	0662057A09	22
R6532	0662057G13	100K
R6555	0662057A33	220
R7534	0662057B47	0
U6501	51MHW2820A	INTEGRATED CIRCUITS: Power Amplifier
U6502	4805921T02	Switch
	8408537Y01 Issue P2	Printed Circuit Board (For Reference Only): For Kit FLF5606A

NOTES:
1. All resistance values are in ohms unless indicated otherwise.
2. Components shown on parts location and schematic diagrams but not included in parts list are not placed.

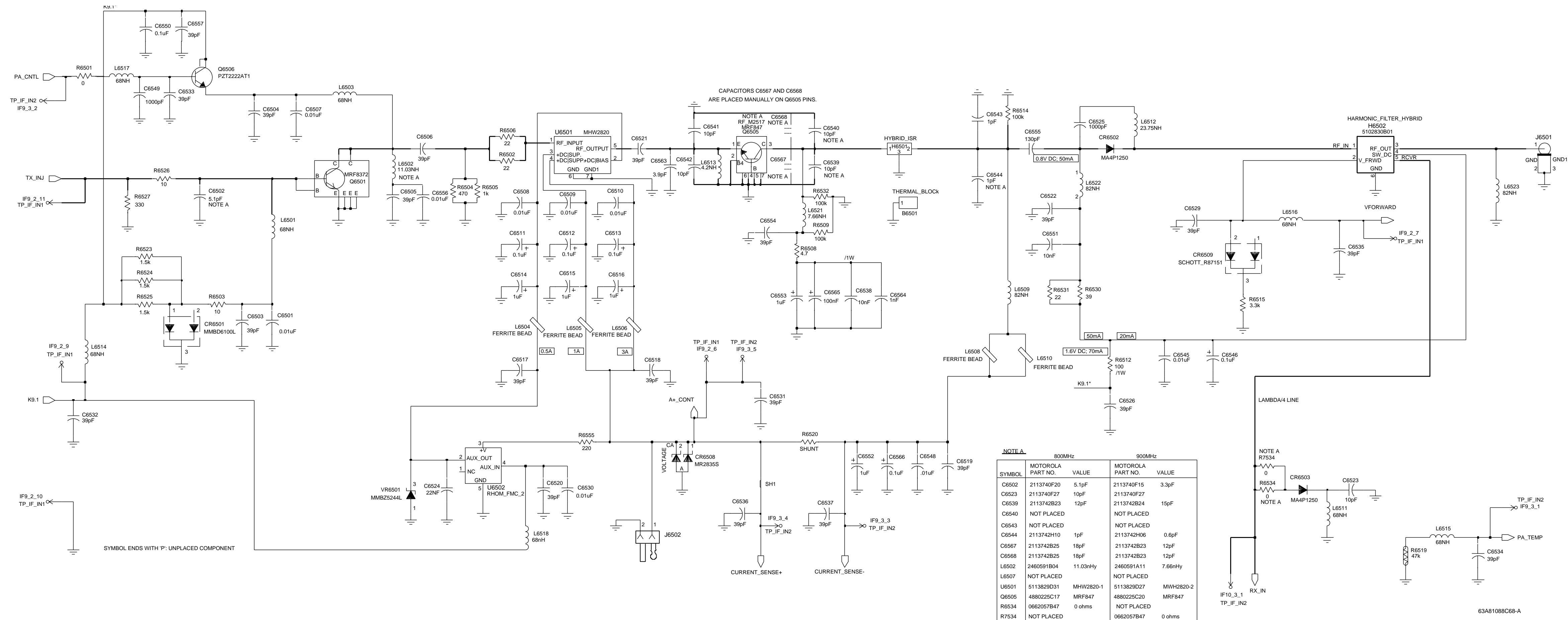

NOTE A

SYMBOL	800MHz		900MHz	
	MOTOROLA PART NO.	VALUE	MOTOROLA PART NO.	VALUE
C6502	2113740F20	5.1pF	2113740F15	3.3pF
C6523	2113740F27	10pF	2113740F27	
C6539	2113742B23	12pF	2113742B24	15pF
C6540	NOT PLACED		NOT PLACED	
C6543	NOT PLACED		NOT PLACED	
C6544	2113742H10	1pF	2113742H06	0.6pF
C6567	2113742B25	18pF	2113742B23	12pF
C6568	2113742B25	18pF	2113742B23	12pF
L6502	2460591B04	11.03nHy	2460591A11	7.66nHy
L6507	NOT PLACED		NOT PLACED	
U6501	5113829D31	MHW2820-1	5113829D27	MHW2820-2
Q6505	4880225C17	MRF847	4880225C20	MRF847
R6534	0662057B47	0 ohms	NOT PLACED	
R7534	NOT PLACED		0662057B47	0 ohms

30-Watt Power Amplifier (Kit FLF5606A)
Schematic Diagram

SYNTHESIZER COMPONENT LOCATIONS

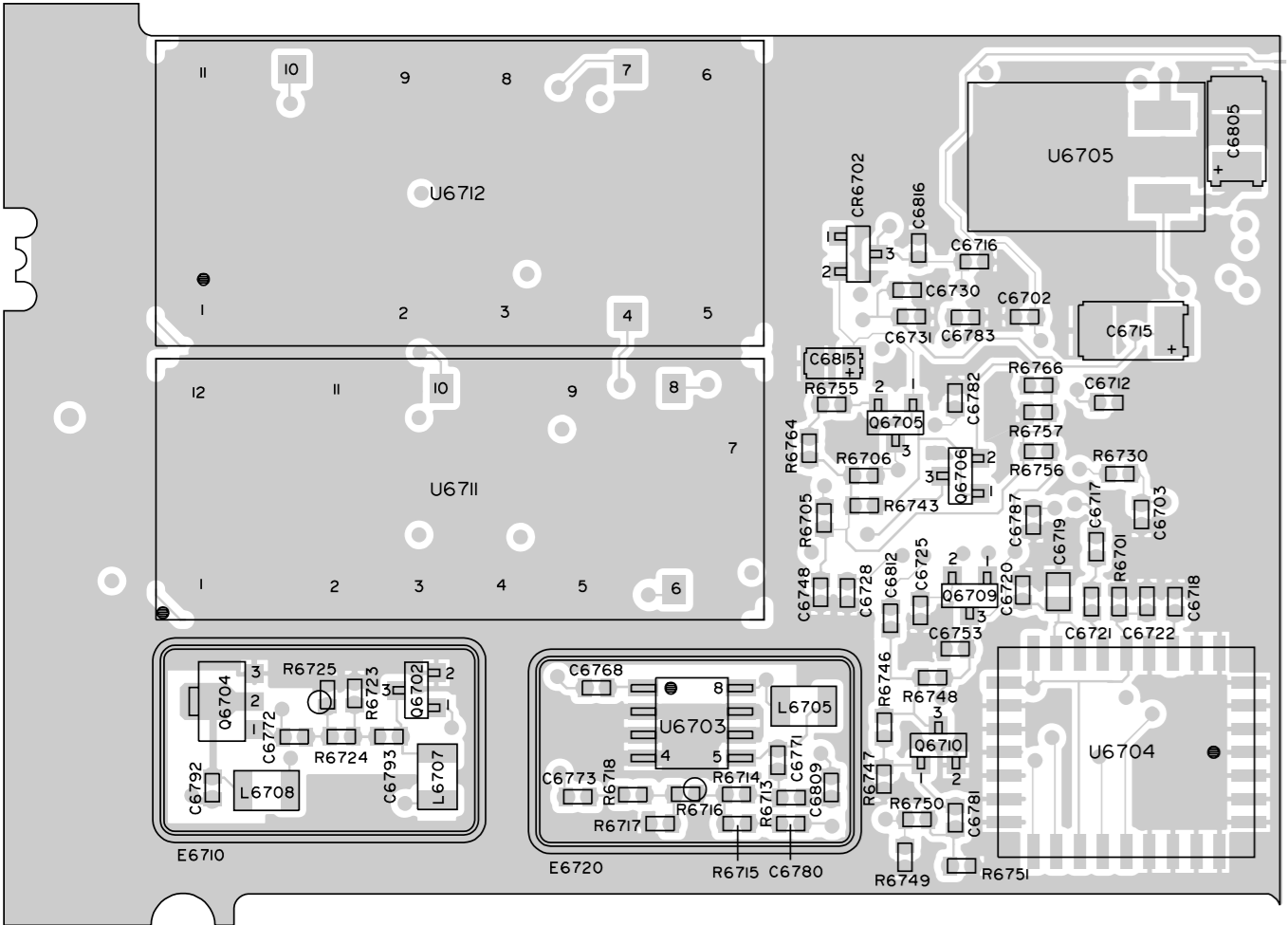

MAEPF-25091-O

HEAVY COMPONENTS SIDE

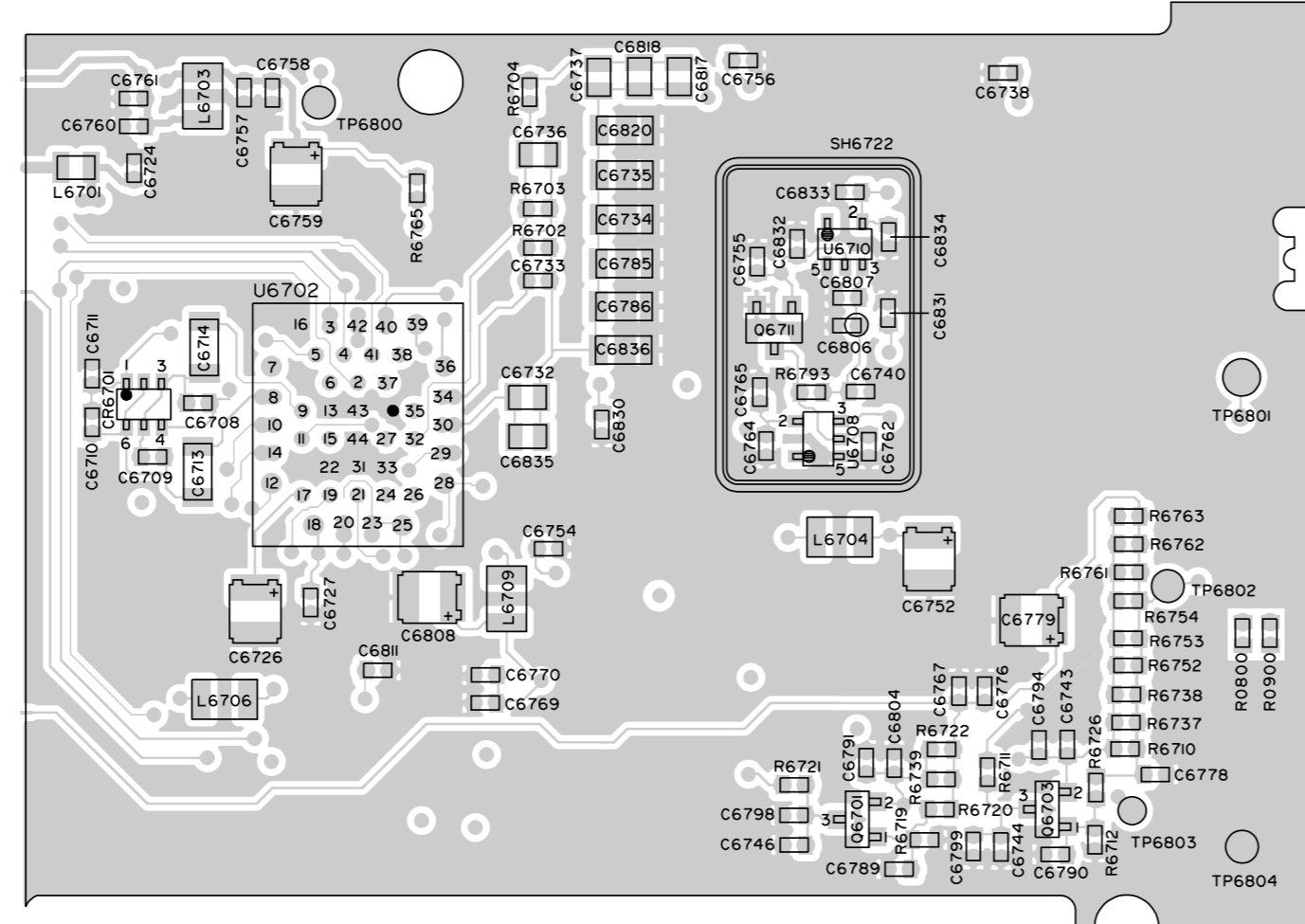

MAEPF-25092-A

LIGHT COMPONENTS SIDE

SYNTHESIZER PARTS LIST

REFERENCE SYMBOL	MOTOROLA PART NO.	DESCRIPTION
CAPACITORS:		
C6702	2113743E07	0.022uF
C6703	2113740F41	39pF
C6708	2113740F41	39pF
C6709	2113740F41	39pF
C6710	2113740F41	39pF
C6711	2113743K15	0.1uF
C6712	2113743K15	0.1uF
C6713	2109720D14	0.1uF
C6714	2109720D14	0.1uF
C6715	2311049A14	4.7uF
C6716	2113743E07	0.022uF
C6717	2113743E07	0.022uF
C6718	2113743E07	0.022uF
C6719	2113741A57	0.033uF
C6720	2113740F41	39pF
C6721	2113740F41	39pF
C6722	2113743E07	0.022uF
C6724	2113743E07	0.022uF
C6725	2113743K15	0.1uF
C6726	2311049J12	4.7uF
C6727	2113740F41	39pF
C6728	2113743K15	0.1uF
C6730	2113740F41	39pF
C6731	2113743E07	0.022uF
C6732	2105248W01	1000pF
C6734	2109720D14	0.1uF
C6735	2109720D14	0.1uF
C6736	2109720D01	0.01uF
C6737	2109720D01	0.01uF
C6738	2113740F41	39pF
C6740	2113740F41	39pF
C6743	2113743K15	0.1uF
C6744	2113743K15	0.1uF
C6752	2311049J12	4.7uF
C6753	2113743K15	0.1uF
C6754	2113743K15	0.1uF
C6755	2113740F41	39pF
C6756	2113743K15	0.1uF
C6757	2113740F41	39pF
C6758	2113743E07	0.022uF
C6759	2311049J12	4.7uF
C6760	2113743E07	0.022uF
C6761	2113743K15	0.1uF
C6762	2113740F41	39pF
C6764	2113740F41	39pF
C6765	2113743E07	0.022uF
C6767	2113740F41	39pF
C6768	2113740F41	39pF
C6769	2113740F41	39pF
C6770	2113743K15	0.1uF
C6771	2113740F41	39pF
C6772	2113740F41	39pF
C6773	2113740F41	39pF
C6776	2113743K15	0.1uF
C6778	2113740F41	39pF
C6779	2311049A09	2.2uF

REFERENCE SYMBOL	MOTOROLA PART NO.	DESCRIPTION
C6780	2113740F41	39pF
C6781	2113740F41	39pF
C6782	2113743K15	0.1uF
C6783	2113743K15	0.1uF
C6785	2109720D14	0.1uF
C6786	2109720D14	0.1uF
C6787	2113743K15	0.1uF
C6789	2113740F41	39pF
C6790	2113740F41	39pF
C6791	2113740F41	39pF
C6792	2113741F49	10nF
C6793	2113740F41	39pF
C6794	2113740F41	39pF
C6798	2113740F41	39pF
C6799	2113740F41	39pF
C6805	2311049J26	10uF
C6806	2113743K15	0.1uF
C6807	2113740F41	39pF
C6808	2311049J12	4.7uF
C6809	2113740F41	39pF
C6811	2113740F41	39pF
C6812	2113740F41	39pF
C6815	2311049A07	1.0uF
C6816	2113741F25	1nF
C6817	2109720D01	0.01uF
C6818	2109720D01	0.01uF
C6820	2109720D14	0.1uF
C6830	2113743K15	0.1uF
C6831	2113740F41	39pF
C6832	2113740F41	39pF
C6833	2113740F41	39pF
C6834	2113743E07	0.022uF
C6836	2109720D14	0.1uF
CR6701	4802233J09	Triple Diode
CR6702	4813833C02	Dual Diode
INDUCTORS:		
L6701	2462587Q44	560nH
L6703	2462587T30	1000nH
L6704	2462587T30	1000nH
L6705	2462587T30	1000nH
L6706	2462587T30	1000nH
L6707	2462587T12	56nH
L6708	2462587T17	150nH
L6709	2462587T30	1000nH
TRANSISTORS:		
Q6701	4813824A17	PNP
Q6702	4882022N70	NPN
Q6703	4813824A17	PNP
Q6704	4882971R01	NPN
Q6705	4813824A17	PNP
Q6706	4813824A17	PNP
Q6709	4813824A17	PNP
Q6710	4882022N70	NPN
Q6711	4880048M01	NPN 47K/47K

REFERENCE SYMBOL	MOTOROLA PART NO.	DESCRIPTION
RESISTORS:		
R0900	0662057B47	0
R6701	0662057A57	2.2K
R6702	0662057A18	51
R6703	0662057A57	2.2K
R6704	0662057A49	1K
R6705	0662057A97	100K
R6706	0662057B09	300K
R6710	0662057A42	510
R6711	0662057A59	2.7K
R6712	0662057A65	4.7K
R6713	0662057A37	330
R6714	0662057A09	22
R6715	0662057A09	22
R6716	0662057A09	22
R6717	0662057A29	150
R6718	0662057A01	10
R6719	0662057A65	4.7K
R6720	0662057A65	4.7K
R6721	0662057A61	3.3K
R6722	0662057A35	270
R6723	0662057A35	270
R6724	0662057A09	22
R6725	0662057A35	270
R6726	0662057A65	4.7K
R6730	0662057A25	100
R6737	0662057A42	510
R6738	0662057A42	510
R6739	0662057A35	270
R6743	0662057A80	20K
R6746	0662057A73	10K
R6747	0662057A53	1.5K
R6748	0662057A37	330
R6749	0662057A25	100
R6750	0662057A18	51
R6751	0662057A25	100
R6752	0662057A42	510
R6753	0662057A42	510
R6754	0662057A42	510
R6755	0662057A81	22K
R6756	0662057A57	2.2K
R6757	0662057A61	3.3K
R6761	0662057A42	510
R6764	0662057A56	2K
R6766	0662057A81	22K
R6793	0662057A65	4.7K
INTEGRATED CIRCUITS:		
U6702	5105625U31	Fractional-N
U6703	5105625U27	NEC MMIC UPC1678G
U6704	5105279V31	16.8MHz Pendulum Oscillator.
U6705	5113816A07	5V Regulator
U6708	4805921T02	Transistor Switch
U6710	4805921T02	Transistor Switch
U6711	5180307L01	Tx VCO
U6712	5180307L02	Rx VCO

REFERENCE SYMBOL	MOTOROLA PART NO.	DESCRIPTION
SH6710	2602660J01	SHIELDS:
SH6720	2602660J01	TX INJ SHIELD
SH6722	2602660J01	TX INJ SHIELD
Printed Circuit Boards (for reference only)		
	8404416P04 Issue P4	For Kits FLF5591A, B, C
	8404994E05 Issue P5	For Kits FLF5592A, B, C
	8408559Y01 Issue P1	For Kit FLF5604A
	8486005J01 Issue P1	For Kit FUF5752A
	8408497Y01 Issue P2	For Kit FLF5952A
	8404416P05 Issue P5	For Kits HUF1190A
	8404994E05 Issue P5	For Kits HUF1191A

NOTES:

- All resistance values are in ohms unless indicated otherwise.
- Components shown on parts location and schematic diagrams but not included in parts list are not placed.

Synthesizer (Kits FLF5591A, B, C; FLF5592A, B, C; FLF5604A; FUF5752A; FLF5952A; FLF5606A; HUF1190A; HUF1191A) Component Locations and Parts List

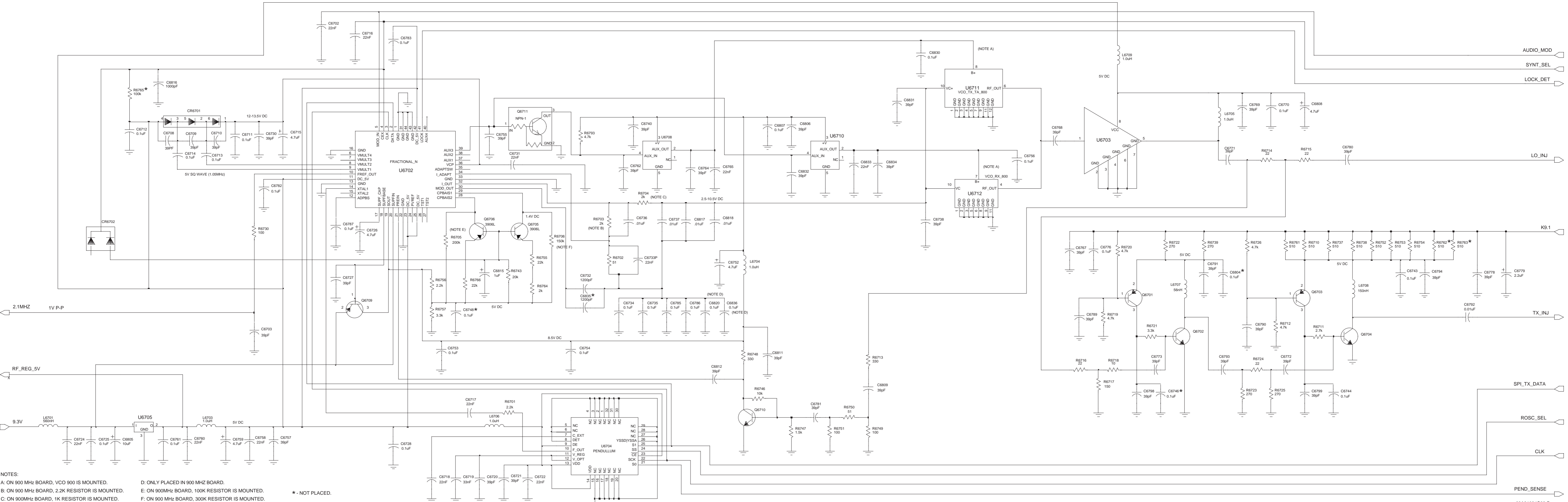

NOTES:
 A: ON 900 MHz BOARD, VCO 900 IS MOUNTED.
 B: ON 900 MHz BOARD, 2.2K RESISTOR IS MOUNTED.
 C: ON 900MHz BOARD, 1K RESISTOR IS MOUNTED.
 D: ONLY PLACED IN 900 MHz BOARD.
 E: ON 900MHz BOARD, 100K RESISTOR IS MOUNTED.
 F: ON 900 MHz BOARD, 300K RESISTOR IS MOUNTED.
 * - NOT PLACED.

63A81084C66-B

Synthesizer (Kits FLF5591A, B, C; FLF5592A, B, C; FLF5604A; FUF5752A; FLF5952A; FLF5606A; HUF1190A; HUF1191A) Schematic Diagram

NOTES

Table 2: Schematic Diagrams Interconnection List

From				To			
Signal Name	Node No.	Schematic Diagram Title	Publication No.	Signal Name	Node No.	Schematic Diagram Title	Publication No.
RX_IN		Receiver Front End	68P81080C44-B	RX_IN		Power Amplifier	68P81080C44-B
LO_INJ		Receiver Front End	68P81080C44-B	LO_INJ		Synthesizer	68P81080C44-B
IF_OUT		Receiver Front End	68P81080C44-B	IF_IN	IF5-1-1	Receiver IF	68P81080C44-B
RF_REG_5V		Receiver Front End	68P81080C44-B			See List of Common Voltages and Signals at End of This Table	
9.3		Receiver Front End	68P81080C44-B			See List of Common Voltages and Signals at End of This Table	
K9.1		Receiver Front End	68P81080C44-B			See List of Common Voltages and Signals at End of This Table	
IF_IN	IF5-1-1	Receiver IF	68P81080C44-B	IF_OUT		Receiver Front End	68P81080C44-B
IF_V_OUT	IF3-2-9	Receiver IF	68P81080C44-B	IF_IN		Receiver Back End	68P81080C44-B
DUPLEX LOCK DETECT	IF1-3-1	Receiver IF	68P81080C44-B				
DUPLEX LOCK DETECT	IF3-2-11	Receiver IF	68P81080C44-B				
RX_CNTL1	IF1-3-6	Receiver IF	68P81080C44-B	RX_CNTL1		Controller, Power Control/Main Controller	68P81083C20-B
RX_CNTL1	IF5-2-3	Receiver IF	68P81080C44-B	RX_CNTL1		Controller, Power Control/Main Controller	68P81083C20-B
RX_CNTL2	IF1-2-16	Receiver IF	68P81080C44-B				
DUPLEX_SYN_SELECT	IF1-2-19	Receiver IF	68P81080C44-B	DUPLEX_SYN_SEL		Controller/Main Controller	68P81083C20-B
GND	IF1-2-14	Receiver IF	68P81080C44-B				
GND	IF1-3-9	Receiver IF	68P81080C44-B				

Table 2: Schematic Diagrams Interconnection List

From				To			
Signal Name	Node No.	Schematic Diagram Title	Publication No.	Signal Name	Node No.	Schematic Diagram Title	Publication No.
GND	IF1-3-7	Receiver IF	68P81080C44-B				
CLK	IF1-3-5	Receiver IF	68P81080C44-B			See List of Common Voltages and Signals at End of This Table	
CLK	IF4-3-1	Receiver IF	68P81080C44-B			See List of Common Voltages and Signals at End of This Table	
CLK	IF3-3-2	Receiver IF	68P81080C44-B			See List of Common Voltages and Signals at End of This Table	
SPI_TX_DATA	IF1-3-4	Receiver IF	68P81080C44-B			See List of Common Voltages and Signals at End of This Table	
SPI_TX_DATA	IF3-3-3	Receiver IF	68P81080C44-B			See List of Common Voltages and Signals at End of This Table	
SPI_TX_DATA	IF4-3-9	Receiver IF	68P81080C44-B			See List of Common Voltages and Signals at End of This Table	
ROSC_SEL	IF1-2-13	Receiver IF	68P81080C44-B	ROSC_SEL		Synthesizer	68P81080C44-B
				ROSC_SEL		Controller/Main Controller	68P81083C20-B
ROSC_SEL	IF4-4-5	Receiver IF	68P81080C44-B	ROSC_SEL		Synthesizer	68P81080C44-B
				ROSC_SEL		Controller/Main Controller	68P81083C20-B
LOCK_DET	IF1-3-11	Receiver IF	68P81080C44-B	LOCK_DET		Synthesizer	68P81080C44-B
				LOCK_DET		Controller/Main Controller	68P81083C20-B
LOCK_DET	IF4-4-3	Receiver IF	68P81080C44-B	LOCK_DET		Synthesizer	68P81080C44-B
				LOCK_DET		Controller/Main Controller	68P81083C20-B
AUDIO_MOD	IF1-2-12	Receiver IF	68P81080C44-B	AUDIO_MOD		Synthesizer	68P81080C44-B
				AUDIO_MOD		Controller, ASFIC/Audio Block Diagram/Main Controller	68P81083C20-B
AUDIO_MOD	IF4-1-6	Receiver IF	68P81080C44-B	AUDIO_MOD		Synthesizer	68P81080C44-B

Table 2: Schematic Diagrams Interconnection List

From				To			
Signal Name	Node No.	Schematic Diagram Title	Publication No.	Signal Name	Node No.	Schematic Diagram Title	Publication No.
				AUDIO_MOD		Controller, ASFIC/Audio Block Diagram/Main Controller	68P81083C20-B
SYN_SEL	IF1-3-10	Receiver IF	68P81080C44-B	SYN_SEL		Controller/Main Controller	68P81083C20-B
SYN_SEL	IF4-3-4	Receiver IF	68P81080C44-B	SYN_SEL		Controller/Main Controller	68P81083C20-B
				SYNT_SEL		Synthesizer	68P81080C44-B
2.1MHZ	IF1-3-8	Receiver IF	68P81080C44-B			See List of Common Voltages and Signals at End of This Table	
2.1MHZ	IF3-3-5	Receiver IF	68P81080C44-B			See List of Common Voltages and Signals at End of This Table	
2.1MHZ	IF4-2-7	Receiver IF	68P81080C44-B			See List of Common Voltages and Signals at End of This Table	
SQUELCH	IF1-2-17	Receiver IF	68P81080C44-B	SQUELCH_IN		Controller, ASFIC/Audio Block Diagram/Main Controller	68P81083C20-B
				SQUELCH		Receiver Back End	68P81080C44-B
SQUELCH	IF3-2-16	Receiver IF	68P81080C44-B	SQUELCH_IN		Controller, ASFIC/Audio Block Diagram/Main Controller	68P81083C20-B
				SQUELCH		Receiver Back End	68P81080C44-B
ZIF_SEL	IF1-2-18	Receiver IF	68P81080C44-B	ZIF_SEL		Controller/Main Controller	68P81083C20-B
ZIF_SEL	IF3-2-1	Receiver IF	68P81080C44-B	ZIF_SEL		Controller/Main Controller	68P81083C20-B
				ZIF_SEL		Receiver Back End	68P81080C44-B
DISC	IF1-3-2	Receiver IF	68P81080C44-B	DISC		Controller, Hear Clear/Audio Block Diagram/Main Controller	68P81083C20-B
				DISC		Receiver Back End	68P81080C44-B

Table 2: Schematic Diagrams Interconnection List

From				To			
Signal Name	Node No.	Schematic Diagram Title	Publication No.	Signal Name	Node No.	Schematic Diagram Title	Publication No.
				DISC		Controller, ASFIC/Audio Block Diagram/Main Controller	68P81083C20-B
DISC	IF3-3-4	Receiver IF	68P81080C44-B	DISC		Controller, Hear Clear/Audio Block Diagram/Main Controller	68P81083C20-B
				DISC		Receiver Back End	68P81080C44-B
				DISC		Controller, ASFIC/Audio Block Diagram/Main Controller	68P81083C20-B
RSSI	IF1-3-3	Receiver IF	68P81080C44-B			See List of Common Voltages and Signals at End of This Table	
RSSI	IF3-3-7	Receiver IF	68P81080C44-B			See List of Common Voltages and Signals at End of This Table	
PEND_TEMP	IF4-4-10	Receiver IF	68P81080C44-B				
9.3	IF1-2-15	Receiver IF	68P81080C44-B			See List of Common Voltages and Signals at End of This Table	
9.3	IF4-4-2	Receiver IF	68P81080C44-B			See List of Common Voltages and Signals at End of This Table	
9.3	IF5-3-2	Receiver IF	68P81080C44-B			See List of Common Voltages and Signals at End of This Table	
RF_REG_5V	IF4-4-8	Receiver IF	68P81080C44-B			See List of Common Voltages and Signals at End of This Table	
RF_REG_5V	IF5-4-4	Receiver IF	68P81080C44-B			See List of Common Voltages and Signals at End of This Table	
RF_REG_5V	IF3-4-8	Receiver IF	68P81080C44-B			See List of Common Voltages and Signals at End of This Table	
IF_IN		Receiver Back End	68P81080C44-B	IF_V_OUT	IF3-2-9	Receiver IF	68P81080C44-B
RF_REG_5V		Receiver Back End	68P81080C44-B			See List of Common Voltages and Signals at End of This Table	

Table 2: Schematic Diagrams Interconnection List

From				To			
Signal Name	Node No.	Schematic Diagram Title	Publication No.	Signal Name	Node No.	Schematic Diagram Title	Publication No.
SQUELCH		Receiver Back End	68P81080C44-B	SQUELCH	IF1-2-17	Receiver IF	68P81080C44-B
				SQUELCH	IF3-2-16	Receiver IF	68P81080C44-B
				SQUELCH_IN		Controller, ASFIC/Audio Block Diagram/Main Controller	68P81083C20-B
DISC		Receiver Back End	68P81080C44-B	DISC		Controller, Hear Clear/audio Block Diagram/Main Controller	68P81083C20-B
				DISC	IF1-3-2	Receiver IF	68P81080C44-B
				DISC	IF3-3-4	Receiver IF	68P81080C44-B
				DISC		Controller, ASFIC/Audio Block Diagram/Main Controller	68P81083C20-B
2.1MHZ		Receiver Back End	68P81080C44-B			See List of Common Voltages and Signals at End of This Table	
ZIF_SEL		Receiver Back End	68P81080C44-B	ZIF_SEL		Controller/Main Controller	68P81083C20-B
				ZIF_SEL	IF1-2-18	Receiver IF	68P81080C44-B
				ZIF_SEL	IF3-2-1	Receiver IF	68P81080C44-B
CLK		Receiver Back End	68P81080C44-B			See List of Common Voltages and Signals at End of This Table	
SPI_TX_DATA		Receiver Back End	68P81080C44-B			See List of Common Voltages and Signals at End of This Table	
RSSI		Receiver Back End	68P81080C44-B			See List of Common Voltages and Signals at End of This Table	
PA_CNTL		Power Amplifier	68P81080C44-B	PA_CNTL		Controller, Power Control/Main Controller	68P81083C20-B
TX_INJ		Power Amplifier	68P81080C44-B	TX_INJ		Synthesizer	68P81080C44-B
K9.1		Power Amplifier	68P81080C44-B			See List of Common Voltages and Signals at End of This Table	

Table 2: Schematic Diagrams Interconnection List

From				To			
Signal Name	Node No.	Schematic Diagram Title	Publication No.	Signal Name	Node No.	Schematic Diagram Title	Publication No.
VDRIVE		Power Amplifier	68P81080C44-B	VDRIVE		Controller, Power Control/Main Controller	68P81083C20-B
TA_EN		Power Amplifier	68P81080C44-B				
A+		Power Amplifier	68P81080C44-B			See List of Common Voltages and Signals at End of This Table	
CURRENT_SENSE+		Power Amplifier	68P81080C44-B	CURRENT_SENSE+		Controller, Power Control/Main Controller	68P81083C20-B
CURRENT_SENSE-		Power Amplifier	68P81080C44-B	CURRENT_SENSE-		Controller, Power Control/Main Controller	68P81083C20-B
VFORWARD		Power Amplifier	68P81080C44-B	V_FORWARD		Controller, Power Control/Main Controller	68P81083C20-B
PA_TEMP		Power Amplifier	68P81080C44-B	PA_TEMP		Controller, Power Control/Main Controller	68P81083C20-B
RX_IN		Power Amplifier	68P81080C44-B	RX_IN		Receiver Front End	68P81080C44-B
2.1MHZ		Synthesizer	68P81080C44-B			See List of Common Voltages and Signals at End of This Table	
RF_REG_5V		Synthesizer	68P81080C44-B			See List of Common Voltages and Signals at End of This Table	
9.3V		Synthesizer	68P81080C44-B			See List of Common Voltages and Signals at End of This Table	
AUDIO_MOD		Synthesizer	68P81080C44-B	AUDIO_MOD	IF1-2-12	Receiver IF	68P81080C44-B
				AUDIO_MOD	IF4-1-6	Receiver IF	68P81080C44-B
				AUDIO_MOD		Controller, ASFIC/audio Block Diagram/Main Controller	68P81083C20-B
SYNT_SEL		Synthesizer	68P81080C44-B	SYN_SEL	IF1-3-10	Receiver IF	68P81080C44-B
				SYN_SEL	IF4-3-4	Receiver IF	68P81080C44-B

Table 2: Schematic Diagrams Interconnection List

From				To			
Signal Name	Node No.	Schematic Diagram Title	Publication No.	Signal Name	Node No.	Schematic Diagram Title	Publication No.
				SYN_SEL		Controller/Main Controller	68P81083C20-B
LOCK_DET		Synthesizer	68P81080C44-B	LOCK_DET		Controller/Main Controller	68P81083C20-B
				LOCK_DET	IF1-3-11	Receiver IF	68P81080C44-B
				LOCK_DET	IF4-4-3	Receiver IF	68P81080C44-B
LO_INJ		Synthesizer	68P81080C44-B	LO_INJ		Receiver Front End	68P81080C44-B
K9.1		Synthesizer	68P81080C44-B			See List of Common Voltages and Signals at End of This Table	
TX_INJ		Synthesizer	68P81080C44-B	TX_INJ		Power Amplifier	68P81080C44-B
SPI_TX_DATA		Synthesizer	68P81080C44-B			See List of Common Voltages and Signals at End of This Table	
ROSC_SEL		Synthesizer	68P81080C44-B	ROSC_SEL	IF1-2-13	Receiver IF	68P81080C44-B
				ROSC_SEL	IF4-4-5	Receiver IF	68P81080C44-B
				ROSC_SEL		Controller/Main Controller	68P81083C20-B
CLK		Synthesizer	68P81080C44-B			See List of Common Voltages and Signals at End of This Table	
PEND_SENSE		Synthesizer	68P81080C44-B				
VDRIVE		Controller, Power Control/ MainController	68P81083C20-B	VDRIVE		Power Amplifier	68P81080C44-B
PWR_RANGE		Controller, Power Control/ MainController	68P81083C20-B	PWR_RANGE		Controller/Main Controller	8P81083C20-B
V_FORWARD		Controller, Power Control/ MainController	68P81083C20-B	VFORWARD		Power Amplifier	68P81080C44-B
VFWD_BUF		Controller, Power Control/ MainController	68P81083C20-B	VFWD_BUF		Audio PA & Voltage Regulators	68P81083C20-B

Table 2: Schematic Diagrams Interconnection List

From				To			
Signal Name	Node No.	Schematic Diagram Title	Publication No.	Signal Name	Node No.	Schematic Diagram Title	Publication No.
VSUM		Controller, Power Control/ Main Controller	68P81083C20-B	VSUM		Audio PA & Voltage Regulators	68P81083C20-B
CLK		Controller, Power Control/ MainController	68P81083C20-B			See List of Common Voltages and Signals at End of This Table	
DA_SEL		Controller, Power Control/ MainController	68P81083C20-B	DA_SEL		Controller/Main Controller	68P81083C20-B
SPI_TX_DATA		Controller, Power Control/ MainController	68P81083C20-B			See List of Common Voltages and Signals at End of This Table	
TEMP_GND		Controller, Power Control/ MainController	68P81083C20-B				
CURRENT_SE NSE+		Controller, Power Control/ Main Controller	68P81083C20-B	CURRENT_ SENSE+		Power Amplifier	68P81080C44-B
CURRENT_SE NSE-		Controller, Power Control/ MainController	68P81083C20-B	CURRENT_ SENSE-		Power Amplifier	68P81080C44-B
PA_TEMP		Controller, Power Control/ MainController	68P81083C20-B	PA_TEMP		Power Amplifier	68P81080C44-B
PA_DIS		Controller, Power Control/ MainController	68P81083C20-B	PA_DIS		Controller/Main Controller	68P81083C20-B
K9.1_ENB		Controller, Power Control/ MainController	68P81083C20-B	K9.1_ENB		Controller/Main Controller	68P81083C20-B
9.3V		Controller, Power Control/ MainController	68P81083C20-B			See List of Common Voltages and Signals at End of This Table	
SW_B+		Controller, Power Control/ MainController	68P81083C20-B			See List of Common Voltages and Signals at End of This Table	
+5V		Controller, Power Control/ MainController	68P81083C20-B			See List of Common Voltages and Signals at End of This Table	
PA_CNTL_LIM		Controller, Power Control/ MainController	68P81083C20-B				

Table 2: Schematic Diagrams Interconnection List

From				To			
Signal Name	Node No.	Schematic Diagram Title	Publication No.	Signal Name	Node No.	Schematic Diagram Title	Publication No.
PA_CNTL		Controller, Power Control/ MainController	68P81083C20-B	PA_CNTL		Power Amplifier	68P81080C44-B
TEMP		Controller, Power Control/ MainController	68P81083C20-B	TEMP		Controller/Main Controller	68P81083C20-B
RX_CNTL1		Controller, Power Control/Main Controller	68P81083C20-B	RX_CNTL1	IF1-3-6	Receiver IF	68P81080C44-B
				RX_CNTL1	IF5-2-3	Receiver IF	68P81080C44-B
K9.1V		Controller, Power Control/ MainController	68P81083C20-B			See List of Common Voltages and Signals at End of This Table	
A+_CONT		Audio PA & Voltage Regulators/ Controller Interface	68P81083C20-B			See List of Common Voltages and Signals at End of This Table	
UNSW_5V		Audio PA & Voltage Regulators	68P81083C20-B	UNSW_+5V		Controller, Emergency Ignition/ Controller Interface/Main Controller	68P81083C20-B
CL_UNSW_5V		Audio PA & Voltage Regulators	68P81083C20-B				
+5V		Audio PA & Voltage Regulators	68P81083C20-B			See List of Common Voltages and Signals at End of This Table	
SW_B+		Audio PA & Voltage Regulators	68P81083C20-B			See List of Common Voltages and Signals at End of This Table	
AUPA_EN		Audio PA & Voltage Regulators	68P81083C20-B	AUPA_EN		Controller/Main Controller	68P81083C20-B
RX_AUDIO		Audio PA & Voltage Regulators	68P81083C20-B	RX_AUDIO		Controller, ASFIC/Audio Block Diagram/Main Controller	68P81083C20-B
SPKR+		Audio PA & Voltage Regulators/ Controller Interface	68P81083C20-B	SPKR+	J0403-1	Controller Interface	68P81083C20-B
SPKR-		Audio PA & Voltage Regulators/ Controller Interface	68P81083C20-B	SPKR-	J0403-3	Controller Interface	68P81083C20-B
					J0405-2	Controller Interface	68P81083C20-B

Table 2: Schematic Diagrams Interconnection List

From				To			
Signal Name	Node No.	Schematic Diagram Title	Publication No.	Signal Name	Node No.	Schematic Diagram Title	Publication No.
A+		Audio PA &Voltage Regulators	68P81083C20-B			See List of Common Voltages and Signals at End of This Table	
B+_ON_OFF		Audio PA &Voltage Regulators/ Controller Interface	68P81083C20-B	B+_ON_OFF		Controller, Emergency Ignition/ Controller Interface/Main Controller	68P81083C20-B
IGNITION_ CLEAR		Audio PA &Voltage Regulators	68P81083C20-B	IGNITION_ CLEAR		Controller/Main Controller	68P81083C20-B
B+_IGNITION		Audio PA &Voltage Regulators/ Controller Interface	68P81083C20-B	B+_IGNITION		Controller, Emergency Ignition/ Controller Interface/Main Controller	68P81083C20-B
9.3		Audio PA &Voltage Regulators	68P81083C20-B			See List of Common Voltages and Signals at End of This Table	
Vdd		Audio PA &Voltage Regulators	68P81083C20-B			See List of Common Voltages and Signals at End of This Table	
Vaud		Audio PA &Voltage Regulators	68P81083C20-B	Vaud		Controller, ASFIC/Audio Block Diagram/Main Controller	68P81083C20-B
PWR_RST		Audio PA &Voltage Regulators	68P81083C20-B	PWR_RST		Controller, ASFIC/Audio Block Diagram/Main Controller	68P81083C20-B
				PWR_RST		Controller/Main Controller	68P81083C20-B
VFWD_BUF		Audio PA &Voltage Regulators	68P81083C20-B	VFWD_BUF		Controller, Power Control/Main Controller	68P81083C20-B
VSUM		Audio PA &Voltage Regulators	68P81083C20-B	VSUM		Controller, Power Control/Main Controller	68P81083C20-B
EXP_FILTERED_ AUDIO		Controller, ASFIC/Audio Block Diagram/Main Controller	68P81083C20-B	EXP_FILTERED_ AUDIO		Controller, Hear Clear/Audio Block Diagram/Main Controller	68P81083C20-B
AUX_RX_IN1		Controller, ASFIC/Audio Block Diagram/Main Controller/Con- troller Interface	68P81083C20-B	AUX_RX_IN1	J0401-9	Controller Interface	68P81083C20-B

Table 2: Schematic Diagrams Interconnection List

From				To			
Signal Name	Node No.	Schematic Diagram Title	Publication No.	Signal Name	Node No.	Schematic Diagram Title	Publication No.
AUX_RX_IN2		Controller, ASFIC/Audio Block Diagram/Main Controller/Controller Interface	68P81083C20-B	AUX_RX_IN2	J0403-12	Controller Interface	68P81083C20-B
AUX_RX_IN3		Controller, ASFIC/Audio Block Diagram/Main Controller/Controller Interface	68P81083C20-B	AUX_RX_IN3	J0408-9	Controller Interface	68P81083C20-B
AUX_TX_IN1		Controller, ASFIC/Audio Block Diagram/Main Controller/Controller Interface	68P81083C20-B	AUX_TX_IN1	J0401-14	Controller Interface	68P81083C20-B
AUX_TX_IN2		Controller, ASFIC/Audio Block Diagram/Main Controller/Controller Interface	68P81083C20-B	AUX_TX_IN2	J0403-24	Controller Interface	68P81083C20-B
AUX_TX_IN3		Controller, ASFIC/Audio Block Diagram/Main Controller/Controller Interface	68P81083C20-B	AUX_TX_IN3	J0408-14	Controller Interface	68P81083C20-B
9.3V		Controller, ASFIC/Audio Block Diagram/Main Controller	68P81083C20-B			See List of Common Voltages and Signals at End of This Table	
VAG		Controller, ASFIC/Audio Block Diagram/Main Controller	68P81083C20-B	VAG		Controller, IO RSSI Buffers Controller Interface/Main Controller	68P81083C20-B
Vaud		Controller, ASFIC/Audio Block Diagram/Main Controller	68P81083C20-B	Vaud		Audio PA & Voltage Regulators	68P81083C20-B
CLK		Controller, ASFIC/Audio Block Diagram/Main Controller	68P81083C20-B			See List of Common Voltages and Signals at End of This Table	
PL_TX		Controller, ASFIC/Audio Block Diagram/Main Controller	68P81083C20-B	PL_TX		Controller/Main Controller	68P81083C20-B
2.1MHZ		Controller, ASFIC/Audio Block Diagram/Main Controller	68P81083C20-B			See List of Common Voltages and Signals at End of This Table	
TX_DATA		Controller, ASFIC/Audio Block Diagram/Main Controller	68P81083C20-B	TX_DATA		Controller/Main Controller	68P81083C20-B

Table 2: Schematic Diagrams Interconnection List

From				To			
Signal Name	Node No.	Schematic Diagram Title	Publication No.	Signal Name	Node No.	Schematic Diagram Title	Publication No.
LG_DTMF		Controller, ASFIC/Audio Block Diagram/Main Controller	68P81083C20-B	LG_DTMF		Controller/Main Controller	68P81083C20-B
ASFIC_SEL		Controller, ASFIC/Audio Block Diagram/Main Controller	68P81083C20-B	ASFIC_SEL		Controller/Main Controller	68P81083C20-B
SPI_TX_DATA		Controller, ASFIC/Audio Block Diagram/Main Controller	68P81083C20-B			See List of Common Voltages and Signals at End of This Table	
EXP_AUDIO		Controller, ASFIC/Audio Block Diagram/Main Controller	68P81083C20-B	EXP_AUDIO		Controller, Hear Clear/Audio Block Diagram/Main Controller	68P81083C20-B
RX_IN		Controller, ASFIC/Audio Block Diagram/Main Controller	68P81083C20-B	RX_IN		Controller, Hear Clear/Audio Block Diagram/Main Controller	68P81083C20-B
TRL_HD2:KEY_FAIL		Controller, ASFIC/Audio Block Diagram/Main Controller	68P81083C20-B	TRL_HD2:KEY_FAIL	J0405-11	Controller Interface	68P81083C20-B
SQUELCH_IN		Controller, ASFIC/Audio Block Diagram/Main Controller	68P81083C20-B	SQUELCH	IF1-2-17	Receiver IF	68P81080C44-B
				SQUELCH	IF3-2-16	Receiver IF	68P81080C44-B
MIC_VOLTAGE		Controller, ASFIC/Audio Block Diagram/Main Controller	68P81083C20-B	MIC_VOLTAGE		Controller, Emergency Ignition/Controller Interface/Main Controller	68P81083C20-B
MIC_IN		Controller, ASFIC/Audio Block Diagram/Main Controller	68P81083C20-B	MIC_IN		Controller, Emergency Ignition/Controller Interface/Main Controller	68P81083C20-B
DISC		Controller, ASFIC/Audio Block Diagram/Main Controller	68P81083C20-B	DISC		Controller, Hear Clear/Audio Block Diagram/Main Controller	68P81083C20-B
				DISC		Receiver IF	68P81080C44-B
				DISC	IF1-3-2	Receiver IF	68P81080C44-B
				DISC	IF3-3-4	Receiver Back End	68P81080C44-B
EXT_MIC_IN		Controller, ASFIC/Audio Block Diagram/Main Controller	68P81083C20-B	EXT_MIC_IN	J0403-23	Controller Interface	68P81083C20-B

Table 2: Schematic Diagrams Interconnection List

From				To			
Signal Name	Node No.	Schematic Diagram Title	Publication No.	Signal Name	Node No.	Schematic Diagram Title	Publication No.
TX_IN		Controller, ASFIC/Audio Block Diagram/Main Controller	68P81083C20-B	TX_IN		Controller, Hear Clear/Audio Block Diagram/Main Controller	68P81083C20-B
RSSI		Controller, ASFIC/Audio Block Diagram/Main Controller	68P81083C20-B			See List of Common Voltages and Signals at End of This Table	
PWR_RST		Controller, ASFIC/Audio Block Diagram/Main Controller	68P81083C20-B	PWR_RST		Audio PA & Voltage Regulators	68P81083C20-B
				PWR_RST		Controller/Main Controller	68P81083C20-B
RX_HI&FIL_ AUDIO_OUT		Controller, ASFIC/Audio Block Diagram/Main Controller	68P81083C20-B	RX_HI&FIL_ AUDIO_OUT	J0403-11	Controller Interface	68P81083C20-B
RX_HI		Controller, ASFIC/Audio Block Diagram/Main Controller	68P81083C20-B	RX_HI	J0405-8	Controller Interface	68P81083C20-B
1200		Controller, ASFIC/Audio Block Diagram/Main Controller	68P81083C20-B	1200		Controller/Main Controller	68P81083C20-B
UP_CLK		Controller, ASFIC/Audio Block Diagram/Main Controller	68P81083C20-B	UP_CLK		Controller/Main Controller	68P81083C20-B
PL_RX		Controller, ASFIC/Audio Block Diagram/Main Controller	68P81083C20-B	PL_RX		Controller/Main Controller	68P81083C20-B
RX_DATA		Controller, ASFIC/Audio Block Diagram/Main Controller	68P81083C20-B	RX_DATA		Controller/Main Controller	68P81083C20-B
RX_AUDIO		Controller, ASFIC/Audio Block Diagram/Main Controller	68P81083C20-B	RX_AUDIO		Audio PA & Voltage Regulators	68P81083C20-B
FILTERED_ AUDIO		Controller, ASFIC/Audio Block Diagram/Main Controller	68P81083C20-B	FILTERED_ AUDIO		Controller, Hear Clear/Audio Block Diagram/Main Controller	68P81083C20-B
ASFIC_MIC_ AUD_OUT		Controller, ASFIC/Audio Block Diagram/Main Controller	68P81083C20-B	ASFIC_MIC_ AUD_OUT		Controller, Hear Clear/Audio Block Diagram/Main Controller	68P81083C20-B
VOX		Controller, ASFIC/Audio Block Diagram/Main Controller	68P81083C20-B	VOX		Controller/Main Controller	68P81083C20-B

Table 2: Schematic Diagrams Interconnection List

From				To			
Signal Name	Node No.	Schematic Diagram Title	Publication No.	Signal Name	Node No.	Schematic Diagram Title	Publication No.
ASFIC_PRE-EMP_OUT		Controller, ASFIC/Audio Block Diagram/Main Controller	68P81083C20-B	ASFIC_PRE-EMP_OUT	J0401-7, J0408-7		68P81083C20-B
AUDIO_MOD		Controller, ASFIC/Audio Block Diagram/Main Controller	68P81083C20-B	AUDIO_MOD	IF1-2-12	Receiver IF	68P81080C44-B
				AUDIO_MOD	IF4-1-6	Receiver IF	68P81080C44-B
				AUDIO_MOD		Synthesizer	68P81080C44-B
FF_EN		Controller, ASFIC/Audio Block Diagram/Main Controller	68P81083C20-B	FF_EN		Controller, Hear Clear/audio Block Diagram/Main Controller	68P81083C20-B
HCI_DIS		Controller, ASFIC/Audio Block Diagram/Main Controller	68P81083C20-B	HCI_DIS		Controller, Hear Clear/audio Block Diagram/Main Controller	68P81083C20-B
LC_DIS		Controller, ASFIC/Audio Block Diagram/Main Controller	68P81083C20-B	LC_DIS		Controller, Hear Clear/audio Block Diagram/Main Controller	68P81083C20-B
COMP_EN		Controller, ASFIC/Audio Block Diagram/Main Controller	68P81083C20-B	COMP_EN		Controller, Hear Clear/audio Block Diagram/Main Controller	68P81083C20-B
HI_CLMP_EN		Controller, ASFIC/Audio Block Diagram/Main Controller	68P81083C20-B	HI_CLMP_EN		Controller, Hear Clear/audio Block Diagram/Main Controller	68P81083C20-B
CH_ACT		Controller, ASFIC/Audio Block Diagram/Main Controller	68P81083C20-B	CH_ACT		Controller/Main Controller	68P81083C20-B
SQ_DET		Controller, ASFIC/Audio Block Diagram/Main Controller	68P81083C20-B	SQ_DET		Controller/Main Controller	68P81083C20-B
UNIV_IO		Controller, ASFIC/Audio Block Diagram/Main Controller	68P81083C20-B	UNIV_IO	J0401-10, J0408-10	Controller Interface	68P81083C20-B
				UNIV_IO		Controller, IO RSSI Buffers/Controller Interface/Main Controller	68P81083C20-B
COMP_EN		Controller, Hear Clear/Audio Block Diagram/Main Controller	68P81083C20-B	COMP_EN		Controller, ASFIC/Audio Block Diagram/Main Controller	68P81083C20-B

Table 2: Schematic Diagrams Interconnection List

From				To			
Signal Name	Node No.	Schematic Diagram Title	Publication No.	Signal Name	Node No.	Schematic Diagram Title	Publication No.
FF_EN		Controller, Hear Clear/audio Block Diagram/Main Controller	68P81083C20-B	FF_EN		Controller, ASFIC/Audio Block Diagram/Main Controller	68P81083C20-B
HI_CLMP_EN		Controller, Hear Clear/Audio Block Diagram/Main Controller	68P81083C20-B	HI_CLMP_EN		Controller, ASFIC/Audio Block Diagram/Main Controller	68P81083C20-B
RSSI		Controller, Hear Clear/Audio Block Diagram/Main Controller	68P81083C20-B			See List of Common Voltages and Signals at End of This Table	
DISC		Controller, Hear Clear/Audio Block Diagram/Main Controller	68P81083C20-B	DISC	IF1-3-2	Receiver IF	68P81080C44-B
				DISC	IF3-3-4	Receiver IF	68P81080C44-B
				DISC		Receiver Back End	68P81080C44-B
				DISC		Controller, ASFIC/Audio Block Diagram/Main Controller	68P81083C20-B
HCI_DIS		Controller, Hear Clear/Audio Block Diagram/Main Controller	68P81083C20-B	HCI_DIS		Controller, ASFIC/Audio Block Diagram/Main Controller	68P81083C20-B
LC_DIS		Controller, Hear Clear/Audio Block Diagram/Main Controller	68P81083C20-B	LC_DIS		Controller, ASFIC/Audio Block Diagram/Main Controller	68P81083C20-B
FILTERED_AUDIO		Controller, Hear Clear/Audio Block Diagram/Main Controller	68P81083C20-B	FILTERED_AUDIO		Controller, ASFIC/Audio Block Diagram/Main Controller	68P81083C20-B
ASFIC_MIC_AUD_OUT		Controller, Hear Clear/Audio Block Diagram/Main Controller	68P81083C20-B	ASFIC_MIC_AUD_OUT		Controller, ASFIC/Audio Block Diagram/Main Controller	68P81083C20-B
9.3V		Controller, Hear Clear/Audio Block Diagram/Main Controller	68P81083C20-B			See List of Common Voltages and Signals at End of This Table	
EXP_FILTERED_AUDIO		Controller, Hear Clear/Audio Block Diagram/Main Controller	68P81083C20-B	EXP_FILTERED_AUDIO		Controller, ASFIC/Audio Block Diagram/Main Controller	68P81083C20-B
EXP_AUDIO		Controller, Hear Clear/Audio Block Diagram/Main Controller	68P81083C20-B	EXP_AUDIO		Controller, ASFIC/Audio Block Diagram/Main Controller	68P81083C20-B

Table 2: Schematic Diagrams Interconnection List

From				To			
Signal Name	Node No.	Schematic Diagram Title	Publication No.	Signal Name	Node No.	Schematic Diagram Title	Publication No.
RX_IN		Controller, Hear Clear/Audio Block Diagram/Main Controller	68P81083C20-B	RX_IN		Controller, ASFIC/Audio Block Diagram/Main Controller	68P81083C20-B
TX_IN		Controller, Hear Clear/Audio Block Diagram/Main Controller	68P81083C20-B	TX_IN		Controller, ASFIC/Audio Block Diagram/Main Controller	68P81083C20-B
UNIV_IO		Controller, IO RSSI Buffers/Controller Interface/Main Controller	68P81083C20-B	UNIV_IO	J0401-10, J0408-10	Controller Interface	68P81083C20-B
				UNIV_IO		Controller, ASFIC/Audio Block Diagram/Main Controller	68P81083C20-B
RSSI		Controller, IO RSSI Buffers/Controller Interface/Main Controller	68P81083C20-B			See List of Common Voltages and Signals at End of This Table	
UNIV_IO_OUT		Controller, IO RSSI Buffers/Controller Interface/Main Controller	68P81083C20-B	BUFFERED DISCRIMINATOR	J0403-25		68P81083C20-B
RSSI_OUT		Controller, IO RSSI Buffers/Controller Interface/Main Controller	68P81083C20-B	RSSI_OUT		Controller/Main Controller	68P81083C20-B
				RSSI_OUT	J0403-22	Controller Interface	68P81083C20-B
9.3V		Controller, IO RSSI Buffers/Controller Interface/Main Controller	68P81083C20-B			See List of Common Voltages and Signals at End of This Table	
Vdd		Controller, IO RSSI Buffers/Controller Interface/Main Controller	68P81083C20-B			See List of Common Voltages and Signals at End of This Table	
VAG		Controller, IO RSSI Buffers/Controller Interface/Main Controller	68P81083C20-B	VAG		Controller, ASFIC/Audio Block Diagram/Main Controller	68P81083C20-B

Table 2: Schematic Diagrams Interconnection List

From				To			
Signal Name	Node No.	Schematic Diagram Title	Publication No.	Signal Name	Node No.	Schematic Diagram Title	Publication No.
MIC_VOLTAGE		Controller, Emergency Ignition/ Controller Interface/Main Controller	68P81083C20-B	MIC_VOLTAGE		Controller, ASFIC/Audio Block Diagram/Main Controller	68P81083C20-B
MIC_IN		Controller, Emergency Ignition/ Controller Interface/Main Controller	68P81083C20-B	MIC_IN		Controller, ASFIC/Audio Block Diagram/Main Controller	68P81083C20-B
EMERGENCY		Controller, Emergency Ignition/ Controller Interface/Main Controller	68P81083C20-B	EMERGENCY	J0403-9	Controller Interface	68P81083C20-B
B+_CTRL		Controller, Emergency Ignition/ Controller Interface/Main Controller	68P81083C20-B	B+_CTRL		Controller/Main Controller	68P81083C20-B
IGNITION		Controller, Emergency Ignition/ Controller Interface/Main Controller	68P81083C20-B	IGNITION	J0403-15	Controller Interface	68P81083C20-B
SW_B+_SENSE		Controller, Emergency Ignition/ Controller Interface/Main Controller	68P81083C20-B	SW_B+_SENSE		Controller/Main Controller	68P81083C20-B
B+_ON_OFF		Controller, Emergency Ignition/ Controller Interface/Main Controller	68P81083C20-B	B+_ON_OFF		Audio PA & Voltage Regulators/ Controller Interface	68P81083C20-B
EMER_OUT		Controller, Emergency Ignition/ Controller Interface/Main Controller	68P81083C20-B	EMER_IN		Controller/Main Controller	68P81083C20-B
A+_SENSE		Controller, Emergency Ignition/ Controller Interface/Main Controller	68P81083C20-B	A+_SENSE		Controller/Main Controller	68P81083C20-B
IGNITION_SENSE		Controller, Emergency Ignition/ Controller Interface/Main Controller	68P81083C20-B	IGNITION_SENSE		Controller/Main Controller	68P81083C20-B

Table 2: Schematic Diagrams Interconnection List

From				To			
Signal Name	Node No.	Schematic Diagram Title	Publication No.	Signal Name	Node No.	Schematic Diagram Title	Publication No.
B+_IGNITION		Controller, Emergency Ignition/ Controller Interface/Main Controller	68P81083C20-B	B+_IGNITION		Audio PA & Voltage Regulators/ Controller Interface	68P81083C20-B
+5V		Controller, Emergency Ignition/ Controller Interface/Main Controller	68P81083C20-B			See List of Common Voltages and Signals at End of This Table	
SW_B+		Controller, Emergency Ignition/ Controller Interface/Main Controller	68P81083C20-B			See List of Common Voltages and Signals at End of This Table	
UNSW_+5V		Controller, Emergency Ignition/ Controller Interface/Main Controller	68P81083C20-B	UNSW_5V		Audio PA & Voltage Regulators	68P81083C20-B
Vdd		Controller, Emergency Ignition/ Controller Interface/Main Controller	68P81083C20-B			See List of Common Voltages and Signals at End of This Table	
BUS-		Controller, SCI Drivers/Control- ler Interface/Main Controller	68P81083C20-B	BUS-	J0405-4, J0403-18	Controller Interface	68P81083C20-B
BUS+		Controller, SCI Drivers/Control- ler Interface/Main Controller	68P81083C20-B	BUS+	J0405-15, J0403-6	Controller Interface	68P81083C20-B
SCI_TX		Controller, SCI Drivers/Control- ler Interface/Main Controller	68P81083C20-B	SCI_TX		Controller/Main Controller	68P81083C20-B
BUSY_OUT		Controller, SCI Drivers/Control- ler Interface/Main Controller	68P81083C20-B	BUSY_OUT		Controller/Main Controller	68P81083C20-B
BUSY		Controller, SCI Drivers/Control- ler Interface/Main Controller	68P81083C20-B	BUSY	J0405-14, J0403-5	Controller Interface	68P81083C20-B
RESET_OUT		Controller, SCI Drivers/Control- ler Interface/Main Controller	68P81083C20-B	RESET_OUT		Controller/Main Controller	68P81083C20-B
LH_RESET		Controller, SCI Drivers/Control- ler Interface/Main Controller	68P81083C20-B	RESET	J0403-17	Controller Interface	68P81083C20-B

Table 2: Schematic Diagrams Interconnection List

From				To			
Signal Name	Node No.	Schematic Diagram Title	Publication No.	Signal Name	Node No.	Schematic Diagram Title	Publication No.
				RESET	J0405-3 (Via Shorting Resistor R0125)	Controller Interface	68P81083C20-B
SCI_RX		Controller, SCI Drivers/Controller Interface/Main Controller	68P81083C20-B	SCI_RX		Controller/Main Controller	68P81083C20-B
SCI_ECHO		Controller, SCI Drivers/Controller Interface/Main Controller	68P81083C20-B	SCI_ECHO		Controller	68P81083C20-B
BUS_SCI		Controller, SCI Drivers/Controller Interface/Main Controller	68P81083C20-B				
BUSY_IN		Controller, SCI Drivers/Controller Interface/Main Controller	68P81083C20-B	BUSY_IN		Controller/Main Controller	68P81083C20-B
RESET_IN		Controller, SCI Drivers/Controller Interface/Main Controller	68P81083C20-B	RESET_IN		Controller/Main Controller	68P81083C20-B
CLOSED_RESET (On Closed Architecture Only)		Controller, SCI Drivers/Controller Interface/Main Controller	68P81083C20-B				
+5V		Controller, SCI Drivers/Controller Interface/Main Controller	68P81083C20-B			See List of Common Voltages and Signals at End of This Table	
Vdd		Controller, SCI Drivers/Controller Interface/Main Controller	68P81083C20-B			See List of Common Voltages and Signals at End of This Table	
IO2		Controller, IO Buffers/Controller Interface/Main Controller	68P81083C20-B	IO2	J0403-16	Controller Interface	68P81083C20-B
OUT2		Controller, IO Buffers/Controller Interface/Main Controller	68P81083C20-B	OUT_2		Controller/Main Controller	68P81083C20-B
IO3		Controller, IO Buffers/Controller Interface/Main Controller	68P81083C20-B	IO3	J0403-21	Controller Interface	68P81083C20-B

Table 2: Schematic Diagrams Interconnection List

From				To			
Signal Name	Node No.	Schematic Diagram Title	Publication No.	Signal Name	Node No.	Schematic Diagram Title	Publication No.
				VPP_PRO GRAM		Controller/Main Controller	68P81083C20-B
OUT3		Controller, IO Buffers/Controller Interface/Main Controller	68P81083C20-B	OUT_3		Controller/Main Controller	68P81083C20-B
IO4		Controller, IO Buffers/Controller Interface/Main Controller	68P81083C20-B	IO4	J0403-20	Controller Interface	68P81083C20-B
OUT4		Controller, IO Buffers/Controller Interface/Main Controller	68P81083C20-B	OUT_4		Controller/Main Controller	68P81083C20-B
IO5		Controller, IO Buffers/Controller Interface/Main Controller	68P81083C20-B	IO5	J0403-8	Controller Interface	68P81083C20-B
OUT5		Controller, IO Buffers/Controller Interface/Main Controller	68P81083C20-B	OUT_5		Controller/Main Controller	68P81083C20-B
IO6		Controller, IO Buffers/Controller Interface/Main Controller	68P81083C20-B	IO6	J0403-7	Controller Interface	68P81083C20-B
OUT6		Controller, IO Buffers/Controller Interface/Main Controller	68P81083C20-B	OUT_6		Controller/Main Controller	68P81083C20-B
IN2		Controller, IO Buffers/Controller Interface/Main Controller	68P81083C20-B	IN_2		Controller/Main Controller	68P81083C20-B
IN3		Controller, IO Buffers/Controller Interface/Main Controller	68P81083C20-B	IN_3		Controller/Main Controller	68P81083C20-B
IN4		Controller, IO Buffers/Controller Interface/Main Controller	68P81083C20-B	IN_4		Controller/Main Controller	68P81083C20-B
IN5		Controller, IO Buffers/Controller Interface/Main Controller	68P81083C20-B	IN_5		Controller/Main Controller	68P81083C20-B
IN6:_RTSBIN		Controller, IO Buffers/Controller Interface/Main Controller	68P81083C20-B	IN_6		Controller/Main Controller	68P81083C20-B
Vdd		Controller, IO Buffers/Controller Interface/Main Controller	68P81083C20-B			See List of Common Voltages and Signals at End of This Table	

Table 2: Schematic Diagrams Interconnection List

From				To			
Signal Name	Node No.	Schematic Diagram Title	Publication No.	Signal Name	Node No.	Schematic Diagram Title	Publication No.
SW_B+		Controller, IO Buffers/Controller Interface/Main Controller	68P81083C20-B			See List of Common Voltages and Signals at End of This Table	
+5V		Controller, IO Buffers/Controller Interface/Main Controller	68P81083C20-B			See List of Common Voltages and Signals at End of This Table	
RX_DATA_IN		Controller/Main Controller	68P81083C20-B	SW_5V:RX_DATA_IN		Controller Interface	68P81083C20-B
RTSB_OUT		Controller/Main Controller	68P81083C20-B	BUF_CH_EN:RTSB_OUT		Controller Interface	68P81083C20-B
RESET*		Controller/Main Controller	68P81083C20-B	RESET*	J0401-12, J0408-12	Controller Interface	68P81083C20-B
PWR_RST		Controller/Main Controller	68P81083C20-B	PWR_RST		Audio PA & Voltage Regulators	68P81083C20-B
				PWR_RST		Controller, ASFIC/Audio Block Diagram/Main Controller	68P81083C20-B
RESET_OUT		Controller/Main Controller	68P81083C20-B	RESET_OUT		Controller, SCI Drivers/Controller Interface/Main Controller	68P81083C20-B
RESET_IN		Controller/Main Controller	68P81083C20-B	RESET_IN		Controller, SCI Drivers/Controller Interface/Main Controller	68P81083C20-B
RX_DATA		Controller/Main Controller	68P81083C20-B	RX_DATA		Controller, ASFIC/Audio Block Diagram/Main Controller	68P81083C20-B
ASN_SEL		Controller/Main Controller	68P81083C20-B				
K9.1_ENB		Controller/Main Controller	68P81083C20-B	K9.1_ENB		Controller, Power Control/Main Controller	68P81083C20-B
OUT_3		Controller/Main Controller	68P81083C20-B	OUT3		Controller, IO Buffers/Controller Interface/Main Controller	68P81083C20-B
OUT_2		Controller/Main Controller	68P81083C20-B	OUT2		Controller, IO Buffers/Controller Interface/Main Controller	68P81083C20-B
AUPA_EN		Controller/Main Controller	68P81083C20-B	AUPA_EN		Audio PA & Voltage Regulators	68P81083C20-B

Table 2: Schematic Diagrams Interconnection List

From				To			
Signal Name	Node No.	Schematic Diagram Title	Publication No.	Signal Name	Node No.	Schematic Diagram Title	Publication No.
JABBA_SEL		Controller/Main Controller	68P81083C20-B	O:JABBA_SEL_ C:DTMF_SEL	J0401-21, J0408-21	Controller Interface	68P81083C20-B
PWR_RANGE		Controller/Main Controller	68P81083C20-B	PWR_RANGE		Controller, Power Control/Main Controller	68P81083C20-B
DA_SEL		Controller/Main Controller	68P81083C20-B	DA_SEL		Controller, Power Control/Main Controller	68P81083C20-B
PL_RX		Controller/Main Controller	68P81083C20-B	PL_RX		Controller, ASFIC/Audio Block Diagram/Main Controller	68P81083C20-B
DUPLEX_SYN_SEL		Controller/Main Controller	68P81083C20-B	DUPLEX_SYN_SELECT	IF1-2-19	Receiver IF	68P81080C44-B
BUF_SPI_DATA: SECURE_SEL		Controller/Main Controller	68P81083C20-B	BUF_SPI_DATA: SECURE_SELECT		Controller Interface	68P81083C20-B
IGNITION_CLEAR		Controller/Main Controller	68P81083C20-B	IGNITION_CLEAR		Audio PA & Voltage Regulators	68P81083C20-B
ZIF_SEL		Controller/Main Controller	68P81083C20-B	ZIF_SEL	IF1-2-18	Receiver IF	68P81080C44-B
				ZIF_SEL	IF3-2-1	Receiver IF	68P81080C44-B
				ZIF_SEL		Receiver BACK-END	68P81080C44-B
OUT_6		Controller/Main Controller	68P81083C20-B	OUT6		Controller, IO Buffers/Controller Interface/Main Controller	68P81083C20-B
BUSY_OUT		Controller/Main Controller	68P81083C20-B	BUSY_OUT		Controller, SCI Drivers/Controller Interface/Main Controller	68P81083C20-B
B+_CTRL		Controller/Main Controller	68P81083C20-B	B+_CTRL		Controller, Emergency Ignition/Controller Interface/Main Controller	68P81083C20-B
LOCK_DET		Controller/Main Controller	68P81083C20-B	LOCK_DET	IF1-3-11	Receiver IF	68P81080C44-B
				LOCK_DET	IF4-4-3	Receiver IF	68P81080C44-B

Table 2: Schematic Diagrams Interconnection List

From				To			
Signal Name	Node No.	Schematic Diagram Title	Publication No.	Signal Name	Node No.	Schematic Diagram Title	Publication No.
				LOCK_DET		Synthesizer	68P81080C44-B
IN_3		Controller/Main Controller	68P81083C20-B	IN3		Controller, IO Buffers/Controller Interface/Main Controller	68P81083C20-B
IN_4		Controller/Main Controller	68P81083C20-B	IN4		Controller, IO Buffers/Controller Interface/Main Controller	68P81083C20-B
ASN_INT		Controller/Main Controller	68P81083C20-B	ASN_INT_OPT_TX	J0401-22, J0408-22	Controller Interface	68P81083C20-B
OUT_5		Controller/Main Controller	68P81083C20-B	OUT5		Controller, IO Buffers/Controller Interface/Main Controller	68P81083C20-B
OUT_4		Controller/Main Controller	68P81083C20-B	OUT4		Controller, IO Buffers/Controller Interface/Main Controller	68P81083C20-B
EMER_IN		Controller/Main Controller	68P81083C20-B	EMER_OUT		Controller, Emergency Ignition/Controller Interface/Main Controller	68P81083C20-B
SW_B+_SENSE		Controller/Main Controller	68P81083C20-B	SW_B+_SENSE		Controller, Emergency Ignition/Controller Interface/Main Controller	68P81083C20-B
DUPLEX_LOCK_DET (Not Connected For Half Duplex)		Controller/Main Controller	68P81083C20-B				
IGNITION_SENSE		Controller/Main Controller	68P81083C20-B	IGNITION_SENSE		Controller, Emergency Ignition/Controller Interface/Main Controller	68P81083C20-B
IN_6		Controller/Main Controller	68P81083C20-B	IN6:_RTSBIN		Controller, IO Buffers/Controller Interface/Main Controller	68P81083C20-B
JABBA_INT		Controller/Main Controller	68P81083C20-B	O:JABBA_INT_C:DTMF_SEL	J0401-20, J0408-20	Controller Interface	68P81083C20-B
SQ_DET		Controller/Main Controller	68P81083C20-B	SQ_DET		Controller, ASFIC/Audio Block Diagram/Main Controller	68P81083C20-B

Table 2: Schematic Diagrams Interconnection List

From				To			
Signal Name	Node No.	Schematic Diagram Title	Publication No.	Signal Name	Node No.	Schematic Diagram Title	Publication No.
IN_5		Controller/Main Controller	68P81083C20-B	IN5		Controller, IO Buffers/Controller Interface/Main Controller	68P81083C20-B
CH_ACT		Controller/Main Controller	68P81083C20-B	CH_ACT		Controller, ASFIC/Audio Block Diagram/Main Controller	68P81083C20-B
IN_2		Controller/Main Controller	68P81083C20-B	IN2		Controller, IO Buffers/Controller Interface/Main Controller	68P81083C20-B
PL_TX		Controller/Main Controller	68P81083C20-B	PL_TX		Controller, ASFIC/Audio Block Diagram/Main Controller	68P81083C20-B
TX_DATA		Controller/Main Controller	68P81083C20-B	TX_DATA		Controller, ASFIC/Audio Block Diagram/Main Controller	68P81083C20-B
LG_DTMF		Controller/Main Controller	68P81083C20-B	LG_DTMF		Controller, ASFIC/Audio Block Diagram/Main Controller	68P81083C20-B
1200		Controller/Main Controller	68P81083C20-B	1200		Controller, ASFIC/Audio Block Diagram/Main Controller	68P81083C20-B
BUSY_IN		Controller/Main Controller	68P81083C20-B	BUSY_IN		Controller, SCI Drivers/Controller Interface/Main Controller	68P81083C20-B
A+_SENSE		Controller/Main Controller	68P81083C20-B	A+_SENSE		Controller, Emergency Ignition/Controller Interface/Main Controller	68P81083C20-B
UP_CLK		Controller/Main Controller	68P81083C20-B	UP_CLK		Controller, ASFIC/Audio Block Diagram/Main Controller	68P81083C20-B
MOD_A_B		Controller/Main Controller	68P81083C20-B	MOD_A_B		Controller Interface	68P81083C20-B
SCI_RX		Controller/Main Controller	68P81083C20-B	SCI_RX		Controller, SCI Drivers/Controller Interface/Main Controller	68P81083C20-B
SCI_TX		Controller/Main Controller	68P81083C20-B	SCI_TX		Controller, SCI Drivers/Controller Interface/Main Controller	68P81083C20-B
SPI_RX_DATA		Controller/Main Controller	68P81083C20-B	SPI_RX_DATA	J0401-19, J0408-19	Controller Interface	68P81083C20-B

Table 2: Schematic Diagrams Interconnection List

From				To			
Signal Name	Node No.	Schematic Diagram Title	Publication No.	Signal Name	Node No.	Schematic Diagram Title	Publication No.
SPI_TX_DATA		Controller/Main Controller	68P81083C20-B			See List of Common Voltages and Signals at End of This Table	
CLK		Controller/Main Controller	68P81083C20-B			See List of Common Voltages and Signals at End of This Table	
PA_DIS		Controller/Main Controller	68P81083C20-B	PA_DIS		Controller, Power Control/Main Controller	68P81083C20-B
RSSI		Controller/Main Controller	68P81083C20-B			See List of Common Voltages and Signals at End of This Table	
RSSI_OUT		Controller/Main Controller	68P81083C20-B	RSSI_OUT		Controller, IO RSSI Buffers/Controller Interface/Main Controller	68P81083C20-B
				RSSI_OUT	J0403-22	Controller Interface	68P81083C20-B
LBAT		Controller/Main Controller	68P81083C20-B	LBAT		Controller Interface	68P81083C20-B
TEMP		Controller/Main Controller	68P81083C20-B	TEMP		Controller, Power Control/Main Controller	68P81083C20-B
VOX		Controller/Main Controller	68P81083C20-B	VOX		Controller, ASFIC/Audio Block Diagram/Main Controller	68P81083C20-B
SYN_SEL		Controller/Main Controller	68P81083C20-B	SYN_SEL	IF1-3-10	Receiver IF	68P81080C44-B
				SYN_SEL	IF4-3-4	Receiver IF	68P81080C44-B
				SYNT_SEL		Synthesizer	68P81080C44-B
ROSC_SEL		Controller/Main Controller	68P81083C20-B	ROSC_SEL	IF1-2-13	Receiver IF	68P81080C44-B
				ROSC_SEL	IF4-4-5	Receiver IF	68P81080C44-B
				ROSC_SEL		Synthesizer	68P81080C44-B
ASFIC_SEL		Controller/Main Controller	68P81083C20-B	ASFIC_SEL		Controller, ASFIC/Audio Block Diagram/Main Controller	68P81083C20-B
VPP_PROGRAM		Controller/Main Controller	68P81083C20-B	IO3		Controller, IO Buffers/Controller Interface/Main Controller	68P81083C20-B

Table 2: Schematic Diagrams Interconnection List

From				To			
Signal Name	Node No.	Schematic Diagram Title	Publication No.	Signal Name	Node No.	Schematic Diagram Title	Publication No.
				IO3	J0403-21	Controller Interface	68P81083C20-B
Vdd		Controller/Main Controller	68P81083C20-B			See List of Common Voltages and Signals at End of This Table	
SW_5V:RX_DATA_IN		Controller Interface	68P81083C20-B	RX_DATA_IN		Controller/Main Controller	68P81083C20-B
BUF_CH_EN:RTSB_OUT		Controller Interface	68P81083C20-B	RTSB_OUT		Controller/Main Controller	68P81083C20-B
O:JABBA_SEL_ C:DTMF_SEL	J0401-21, J0408-21	Controller Interface	68P81083C20-B	JABBA_SEL		Controller/Main Controller	68P81083C20-B
BUF_SPI_DATA :SECURE_SELECT		Controller Interface	68P81083C20-B	BUF_SPI_DATA :SECURE_SEL		Controller/Main Controller	68P81083C20-B
O:JABBA_INT_ C:DTMF_SEL	J0401-20, J0408-20	Controller Interface	68P81083C20-B	JABBA_INT		Controller/Main Controller	68P81083C20-B
MOD_A_B		Controller Interface	68P81083C20-B	MOD_A_B		Controller/Main Controller	68P81083C20-B
SPI_RX_DATA	J0401-19, J0408-19	Controller Interface	68P81083C20-B	SPI_RX_DATA		Controller/Main Controller	68P81083C20-B
RSSI_OUT	J0403-22	Controller Interface	68P81083C20-B	RSSI_OUT		Controller, IO RSSI Buffers/ Controller Interface/Main Controller	68P81083C20-B
				RSSI_OUT		Controller/Main Controller	68P81083C20-B
LBAT		Controller Interface	68P81083C20-B	LBAT		Controller/Main Controller	68P81083C20-B
Common Voltages and Signals							
A+		Power Amplifier	68P81080C44-B				
		Audio PA & Voltage Regulators	68P81083C20-B				
SW_B+		Controller, Power Control	68P81083C20-B				

Table 2: Schematic Diagrams Interconnection List

From				To			
Signal Name	Node No.	Schematic Diagram Title	Publication No.	Signal Name	Node No.	Schematic Diagram Title	Publication No.
		Audio PA & Voltage Regulators	68P81083C20-B				
		Controller, Emergency Ignition	68P81083C20-B				
		Controller, IO Buffers	68P81083C20-B				
+5V		Controller, Power Control	68P81083C20-B				
		Audio PA & Voltage Regulators	68P81083C20-B				
		Controller, Emergency Ignition	68P81083C20-B				
		Controller, SCI Drivers	68P81083C20-B				
		Controller, IO Buffers	68P81083C20-B				
9.3V		Receiver Front End	68P81080C44-B				
		Receiver IF	68P81080C44-B				
		Controller, Power Control	68P81083C20-B				
		Audio PA & Voltage Regulators	68P81083C20-B				
		Controller, ASFIC	68P81083C20-B				
		Controller, HEAR CLEAR	68P81083C20-B				
		Controller, IO RSSI Buffers	68P81083C20-B				
		Synthesizer	68P81080C44-B				
Vdd		Audio PA & Voltage Regulators	68P81083C20-B				
		Controller, IO RSSI Buffers	68P81083C20-B				
		Controller, Emergency Ignition	68P81083C20-B				
		Controller, SCI Drivers	68P81083C20-B				
		Controller, IO Buffers	68P81083C20-B				

Table 2: Schematic Diagrams Interconnection List

From				To			
Signal Name	Node No.	Schematic Diagram Title	Publication No.	Signal Name	Node No.	Schematic Diagram Title	Publication No.
		Controller	68P81083C20-B				
RF_REG_5V		Receiver Front End	68P81080C44-B				
	IF4-4-8	Receiver IF	68P81080C44-B				
		Receiver Back End	68P81080C44-B				
		Synthesizer	68P81080C44-B				
K9.1		Receiver Front End	68P81080C44-B				
		Power Amplifier	68P81080C44-B				
		Synthesizer	68P81080C44-B				
		Controller, Power Control/Main Controller	68P81083C20-B				
CLK	IF1-3-5	Receiver IF	68P81080C44-B				
		Receiver Back End	68P81080C44-B				
		Synthesizer	68P81080C44-B				
		Controller, Power Control/Main Controller	68P81083C20-B				
		Controller, ASFIC/Audio Block Diagram/Main Controller	68P81083C20-B				
		Controller/Main Controller	68P81083C20-B				
2.1MHZ	IF1-3-8	Receiver IF	68P81080C44-B				
		Receiver Back End	68P81080C44-B				
		Synthesizer	68P81080C44-B				
		Controller, ASFIC/Audio Block Diagram/Main Controller	68P81083C20-B				

Table 2: Schematic Diagrams Interconnection List

From				To			
Signal Name	Node No.	Schematic Diagram Title	Publication No.	Signal Name	Node No.	Schematic Diagram Title	Publication No.
SPI_TX_DATA	IF1-3-4	Receiver IF	68P81080C44-B				
	IF3-3-3	Receiver IF	68P81080C44-B				
	IF4-3-9	Receiver IF	68P81080C44-B				
		Receiver Back End	68P81080C44-B				
		Synthesizer	68P81080C44-B				
		Controller, Power Control/Main Controller	68P81083C20-B				
			68P81083C20-B				
		Controller/Main Controller	68P81083C20-B				
RSSI	IF1-3-3	Receiver IF	68P81080C44-B				
	IF3-3-7	Receiver IF	68P81080C44-B				
		Receiver Back End	68P81080C44-B				
		Controller, ASFIC/Audio Block Diagram/Main Controller	68P81083C20-B				
		Controller, Hear Clear/Audio Block Diagram/Main Controller	68P81083C20-B				
		Controller, IO RSSI Buffers/Controller Interface/Main Controller	68P81083C20-B				
		Controller/Main Controller	68P81083C20-B				
Connector Signals:							
Option Connectors J0401, J0408							
A+_CONT		Controller Interface	68P81083C20-B				

Table 2: Schematic Diagrams Interconnection List

From				To			
Signal Name	Node No.	Schematic Diagram Title	Publication No.	Signal Name	Node No.	Schematic Diagram Title	Publication No.
Vdd		Controller Interface	68P81083C20-B				
2.1MHZ		Controller Interface	68P81083C20-B				
GND		Controller Interface	68P81083C20-B				
DISC		Controller Interface	68P81083C20-B				
9.3V		Controller Interface	68P81083C20-B				
ASFIC_PREAM P_OUT		Controller Interface	68P81083C20-B				
ASFIC_MIC_AU DIO_IN		Controller Interface	68P81083C20-B				
AUX_RX_IN1 - J0401. AUX_RX_IN3 - J0408		Controller Interface	68P81083C20-B				
UNIV_IO		Controller Interface	68P81083C20-B				
GND		Controller Interface	68P81083C20-B				
RESET*		Controller Interface	68P81083C20-B				
CTRL_HD2:KEY _FAIL		Controller Interface	68P81083C20-B				
AUX_TX_IN1 - J0401, AUX_TX_IN3 - J0408.		Controller Interface	68P81083C20-B				
GND:RX_DATA _KID		Controller Interface	68P81083C20-B				
CLK:RTS_DVP_ WE		Controller Interface	68P81083C20-B				

Table 2: Schematic Diagrams Interconnection List

From				To			
Signal Name	Node No.	Schematic Diagram Title	Publication No.	Signal Name	Node No.	Schematic Diagram Title	Publication No.
CLK		Controller Interface	68P81083C20-B				
SPI_TX_DATA		Controller Interface	68P81083C20-B				
SPI_RX_DATA		Controller Interface	68P81083C20-B				
O:JABBA_INT_C:DTMF_DATA_READY		Controller Interface	68P81083C20-B				
O:JABBA_SEL_C:DTMF_SEL		Controller Interface	68P81083C20-B				
ASN_INT_OPT_TX		Controller Interface	68P81083C20-B				
ASN_SEL_OPT_CTSS		Controller Interface	68P81083C20-B				
NC		Controller Interface	68P81083C20-B				
RSSI		Controller Interface	68P81083C20-B				
GND		Controller Interface	68P81083C20-B				
GND		Controller Interface	68P81083C20-B				
Accessory Connector J0403							
SPK+		Controller Interface	68P81083C20-B				
INT_SPK+		Controller Interface	68P81083C20-B				
SPK-		Controller Interface	68P81083C20-B				
GND		Controller Interface	68P81083C20-B				
BUSY		Controller Interface	68P81083C20-B				
BUS+		Controller Interface	68P81083C20-B				

Table 2: Schematic Diagrams Interconnection List

From				To			
Signal Name	Node No.	Schematic Diagram Title	Publication No.	Signal Name	Node No.	Schematic Diagram Title	Publication No.
IO_6		Controller Interface	68P81083C20-B				
IO_5		Controller Interface	68P81083C20-B				
EMERGENCY		Controller Interface	68P81083C20-B				
GND		Controller Interface	68P81083C20-B				
RX_HI:FIL_AUD IO		Controller Interface	68P81083C20-B				
AUX_RX_IN2		Controller Interface	68P81083C20-B				
MIC_IN		Controller Interface	68P81083C20-B				
SW_B+		Controller Interface	68P81083C20-B				
IGNITION		Controller Interface	68P81083C20-B				
IO_2		Controller Interface	68P81083C20-B				
RESET		Controller Interface	68P81083C20-B				
BUS-		Controller Interface	68P81083C20-B				
SCI_RX_DATA		Controller Interface	68P81083C20-B				
IO_4		Controller Interface	68P81083C20-B				
IO_3		Controller Interface	68P81083C20-B				
RSSI_OUT		Controller Interface	68P81083C20-B				
EXTERNAL_MI C_IN		Controller Interface	68P81083C20-B				
AUX_TX_IN2		Controller Interface	68P81083C20-B				
BUFFERED_ DISCRIMINA- TOR		Controller Interface	68P81083C20-B				

Table 2: Schematic Diagrams Interconnection List

From				To			
Signal Name	Node No.	Schematic Diagram Title	Publication No.	Signal Name	Node No.	Schematic Diagram Title	Publication No.
Control Head Connector J0405							
INT_SPK+		Controller Interface	68P81083C20-B				
SPK-		Controller Interface	68P81083C20-B				
MON_BUSY:RE SET		Controller Interface	68P81083C20-B				
PTT:BUS-		Controller Interface	68P81083C20-B				
BUF_SPI_CLK: GND		Controller Interface	68P81083C20-B				
BUF_SPI_DATA :SECURE_ SELECT		Controller Interface	68P81083C20-B				
GND		Controller Interface	68P81083C20-B				
RX_HI		Controller Interface	68P81083C20-B				
MIC_IN		Controller Interface	68P81083C20-B				
CTRL_HD1:WE		Controller Interface	68P81083C20-B				
CTRL_HD2:KEY _FAIL		Controller Interface	68P81083C20-B				
CH_EN:KID		Controller Interface	68P81083C20-B				
VOLUME		Controller Interface	68P81083C20-B				
OPT_SW_B+:B USY		Controller Interface	68P81083C20-B				
AUX:BUS+		Controller Interface	68P81083C20-B				
SW_5V		Controller Interface	68P81083C20-B				

Table 2: Schematic Diagrams Interconnection List

From				To			
Signal Name	Node No.	Schematic Diagram Title	Publication No.	Signal Name	Node No.	Schematic Diagram Title	Publication No.
A+		Controller Interface	68P81083C20-B				
SW_B+		Controller Interface	68P81083C20-B				

Cut along dotted line

SERVICE MANUAL QUESTIONNAIRE

We believe that reports from users provide valuable information for producing quality manuals. By taking a few moments to answer the following questions as they relate to this specific manual, you can take an active role in the continuing effort to ensure that our manuals contain the most accurate and complete information of benefit to you. Thank you for your cooperation.

In reference to Manual Number: 68P81080C44-B

MCS 2000™ Mobile Radio

1. Please check all the appropriate boxes:

	Complete	Incomplete	Correct	Incorrect	Clear	Confusing	Size Adequate	Size Too Small	Not Covered in This Manual
Disassembly Procedures									
Alignment Procedures									
Exploded Views									
Schematic Diagrams									
Circuit Board Details									
Electrical Parts Lists									
Exploded View Parts List									

2. How would you rate the overall organization of this manual?

- excellent
 very good
 good
 fair
 poor

3. Did this Service manual provide you with the information necessary to service and maintain the specific equipment?

- very much so
 generally yes
 to some extent
 no

4. How do you rate this particular Service Manual?

- excellent
 very good
 good
 fair
 poor

5. We would appreciate any corrections or recommendations for improving this manual. Please include the specific page number(s) of the diagram or procedure in question.

- a. Disassembly Procedures:(Page No. _____)
- b. Alignment Procedures:(Page No. _____)
- c. Exploded Views:(Page No. _____)

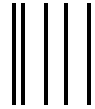

NO POSTAGE
NECESSARY
IF MAILED
IN THE
UNITED STATES

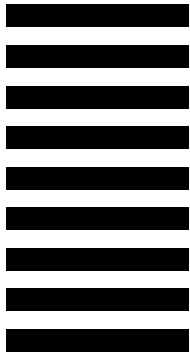

BUSINESS REPLY MAIL
FIRST CLASS MAIL PERMIT NO 9040 FT. LAUDERDALE, FL

POSTAGE WILL BE PAID BY ADDRESSEE



MOTOROLA

Attention: Media and Communication
8000 W. Sunrise Boulevard
Ft. Lauderdale, FL 33322



FOLD

FOLD

(Continued)

Please specify the page number along with any corrections or recommendations for improvement.

- d. Schematic Diagrams: (Page No. _____)
- e. Component Location Details: (Page No. _____)
- f. Electrical Parts List: (Page No. _____)
- g. Exploded View Parts List: (Page No. _____)

6. General comments/suggestions:

Name:.....

Company:.....

Customer COSC MSS FTR Other

Address:

City/State/Zip:.....

Phone Number (Please include Area Code):

PLEASE USE TAPE TO SEAL

POSTAL REGULATIONS PROHIBIT USE OF STAPLES

REPLACEMENT PARTS ORDERING

ORDERING INFORMATION

When ordering replacement parts or equipment information, the complete identification number should be included. This applies to all components, kits, and chassis. If the component part number is not known, the order should include the number of the chassis or kit of which it is a part, and sufficient description of the desired component to identify it.

Crystal and channel element orders should specify the crystal or channel element type number, crystal and carrier frequency, and the model number in which the part is used.

MAIL ORDERS

Send written orders to the following addresses:

Replacement Parts/
Test Equipment/Manuals/
Crystal Service Items:

Motorola Inc.
United States and Canada
Accessories and Aftermarket
Division
Attention: Order Processing
1313 E. Algonquin Road
Schaumburg, IL 60196

Federal Government Orders:

Motorola Inc.
United States and Canada
Accessories and Aftermarket
Division
Attention: Order Processing
7230 Parkway Drive
Landover, MD 21076

International Orders:

Motorola Inc.
United States and Canada
Accessories and Aftermarket
Division
Attention: International Order
Processing
1313 E. Algonquin Road
Schaumburg, IL 60196

TELEPHONE ORDERS

United States and Canada Accessories and Aftermarket Division:
Call: 1-800-422-4210
1-800-826-1913 (For Federal Government Orders)
1-847-538-8023 (International Orders)

Servicers Training (VHS Video Tapes):
Call: 847-576-2828

FAX ORDERS

United States and Canada Accessories and Aftermarket Division:
FAX: 847-538-8198 (Domestic)
847-576-3023 (International)
Parts ID: 847-538-8194

Federal Government Orders:
FAX: 410-712-4991
International: 410-712-6200

PARTS CUSTOMER SERVICE

United States and Canada Accessories and
Aftermarket Division:
Call: 1-800-422-4210
Parts Identification:
Call: 847-538-0021

PRODUCT CUSTOMER SERVICE

Customer Response Center
(Sales and Service Assistance):
Call: 1-800-247-2346
FAX: 1-800-232-9272



**MCS 2000 Mobile Radio Service Instructions
900-MHz Frequency Range Specific
Publication Number 68P81080C44-B**



6881080C44-B